

XM670K-XM679K

Controllers for Multiplexed Cabinets



Copeland
1065 Big Shanty Road NW, Suite 100
Kennesaw, GA 30144 USA
770-425-2724 • 1-800-829-2724
www.copeland.com
Email: ColdChain.TechnicalServices@copeland.com

1 INTRODUCTION..... 1

1.1. General Warning..... 1

2 OVERVIEW 1

2.1. How to Check the Software Release of the XM679K..... 1

2.2. General Description..... 1

2.3. Ordering Codes..... 2

3 USER INTERFACE 3

3.1. Keys and Functions 3

3.2. Use of LEDS 3

3.3. How to Enter the Fast Access Menu..... 4

3.4. How to See the MAX and MIN Temperature Recorded 4

3.5. How to See and Modify the Setpoint 4

3.6. How to Start a Manual Defrost 4

3.7. How to Enter the Parameters List PR1 4

3.8. How to Enter the Parameters List PR2 4

3.9. How to Assign a MODBUS Address 5

3.10. How to Change the Parameter Value..... 5

3.11. ON/OFF Function..... 5

4 FAST ACCESS MENU..... 6

5 SECTION MENU 7

5.1. To Set Energy Saving Times 7

5.2. To Set Timed Defrost Parameters 7

6 ELECTRONIC EXPANSION VALVE MENU (FOR MODEL XM679 ONLY) 8

7 CONTROLLING LOADS..... 8

7.1. Solenoid Valve..... 8

7.2. Standards Regulation and Continuous Regulation 8

7.2.1. First Kind of Regulation: Standard Regulation 9

7.2.2. Second Kind of Regulation: Continuous Regulation (For Model XM679 Only) 9

7.3. Defrost..... 9

7.3.1. Defrost starting 9

7.3.2. Defrost Ending..... 9

7.4. Fans..... 10

7.4.1. Control With Relay 10

7.4.2. Control With Analog Output (If Present) 10

7.5. Anti-Sweat Heaters (If Present) 10

7.6. Auxiliary Output 10

8 PARAMETERS LIST..... 11

9 DIGITAL INPUTS..... 20

9.1. Generic Alarm (EAL) 20

9.2. Serious Alarm Mode (bAL)..... 20

9.3. Pressure Switch (PAL)..... 20

9.4. Door Switch Input (dor) 20

9.5. Start Defrost (dEF) 20

9.6. Relay Aux Actuation (AUS) 20

9.7. Relay Light Actuation (LiG) 20

9.8. Remote ON/OFF (OnF)..... 20

9.9. Kind of Action (Htr) 21

9.10. FHU (Not Used) 21

9.11. Energy Saving Input (ES) 21

9.12. Configurable Input - Holiday Function (HDY) 21

9.13. Digital Inputs Polarity 21

10 INSTALLATION AND MOUNTING..... 21

11 ELECTRICAL CONNECTIONS..... 22

11.1. Probe Connections 22

12 RS485 SERIAL LINE..... 22

13 HOW TO USE THE HOT KEY 22

13.1. Download (From the Hotkey to the Device) 22

13.2. Upload (From the Device to the Hotkey)..... 23

14 ALARM SIGNALS 24

14.1. EE Alarm..... 25

14.2. Alarm Recovery 25

15 TECHNICAL DATA 26

16 UL RATINGS 27

17 CONNECTIONS..... 28

17.1. E2 to XM Device Communication Recommendations 28

 17.1.1. Wiring Guidelines 28

17.2. XM670 - Wiring Diagram 28

17.3. XM679 - 230VAC Valves/Wiring Diagram 29

17.4. XM679 - 24VAC Valves/Wiring Diagram 29

18 E2 MODBUS NETWORK WIRING..... 30

19 WIRING LAYOUT FOR SHARING A PRESSURE TRANSDUCER ON A LAN..... 31

20 PRESSURE TRANSDUCER SETUP (XM679 ONLY) 32

20.1. Keyboard Display CX660..... 32

20.2. Synchronized Defrost..... 33

20.3. Sensors for Superheat Control 33

20.4. Analog Output 33

20.5. RS485 Net Monitoring Temperatures 33

 20.5.1. RS485 Connection 33

20.6. How to Enable a Pressure Probe to Share Across the LAN 34

21 WIRING CONNECTION TO SITE SUPERVISOR..... 35

22 MODBUS NETWORKING TO E2s..... 36

22.1. COM Port Associations - E2 Versions 3.xx and Below..... 36

22.2. COM Port Associations - E2 Versions 4.0 and Above 36

22.3. E2 Setup of Devices 37

 22.3.1. Set Up Network Ports..... 37

 22.3.2. Add and Connect the Device 37

22.4. Wiring Types 39

22.5. MODBUS Termination Blocks 39

23 DEFAULT SETTING VALUES..... 40

APPENDIX A - ALTERNATE MODBUS WIRING METHOD FOR E2, XR, XM, AND XEV DEVICES... 47

1 Introduction

1.1 General Warning

Please read the following safety precautions and warnings before using this manual:

CAUTION

- This manual is part of the product and should be kept near the device for easy and quick reference.
- The device should not be used for purposes different from those described in this manual. It cannot be used as a safety device.
- Check the application limits before proceeding.

CAUTION

SAFETY PRECAUTIONS AND WARNINGS!

- Check that the supply voltage is correct before connecting the device.
- Do not expose to water or moisture: use the controller only within the operating limits and avoid sudden temperature changes with high atmospheric humidity to prevent condensation from forming.
- Warning! Disconnect all electrical connections before performing any kind of maintenance.
- Fit the probe where it is not accessible by the end user. The device must not be opened.
- In case of failure or faulty operation, send the device back to the distributor or to Copeland (see address) with a detailed description of the fault.
- Verify the maximum current that can be applied to each relay (see **Section 15, Technical Data**).
- Ensure that the wires for probes, loads, and the power supply are separated and far enough from each other without crossing or intertwining.
- In case of applications in industrial environments, the use of main filters in parallel with inductive loads could be useful.

2 Overview

2.1 How to Check the Software Release of the XM679K

1. Check the software release of the XM679K printed on the label of the controller.

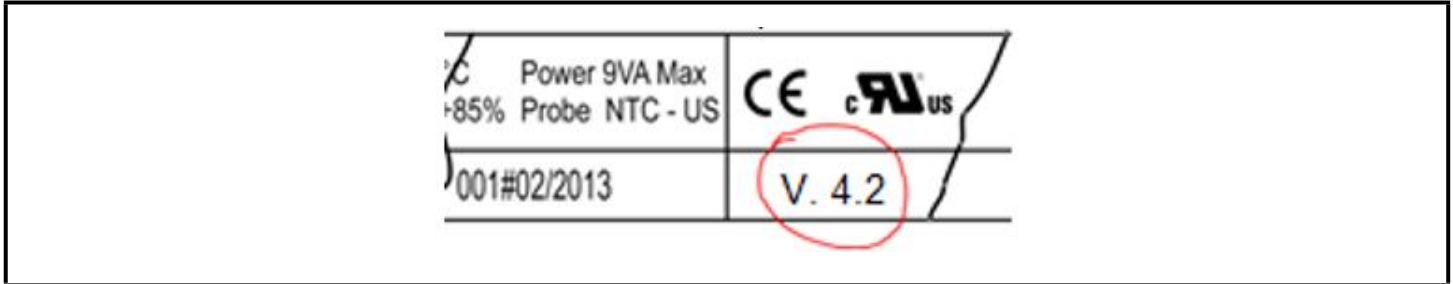

Figure 2-1 - XM679K Software Release

2.2 General Description

Models XM670-XM679 are high level microprocessor based controllers for multiplexed cabinets, suitable for applications on medium or low temperature. It can be inserted in a Local Area Connection (LAN) of up to eight (8) different sections that can operate depending on the programming, as stand alone controllers or by following the commands coming from the other sections.

XM670/XM679 controllers can have six (6) relay outputs to control the solenoid valve, defrost that can be either electrical or hot gas, evaporator fans, lights, auxiliary output, alarm output and an output to drive pulsed electronic expansion valves (applicable for XM679 only).

The controllers can also have up to four (4) probe inputs: the first one for temperature control, the second for defrost end temperature control of the evaporator, the third for the display, and the fourth probe input can be used for applications with virtual probe or for inlet/outlet air temperature measurement. Model XM679 can exclusively have two (2) other probes that can be used for superheat measurement and regulation. Both XM670 and XM679 controllers are also equipped with three digital inputs (free contact) that are fully configurable through parameters.

The Hot Key connector allows simple programming of the controllers. Direct serial output RS485 MODBUS-RTU compatible permits a simple XWEB interfacing. Depending on the model, the Hot Key connector can also be used to connect X-REP display.

2.3 Ordering Codes

Table 2-1 - Product Ordering Codes

Device Name	Description	Copeland Part Number
XM670	Solenoid Case Control 115V	318-6521
XM670	Solenoid Case Control 230V	318-6520
XM679	Pulse Case Control 115V	318-6700
XM679	Pulse Case Control 230V	318-6701

3 User Interface

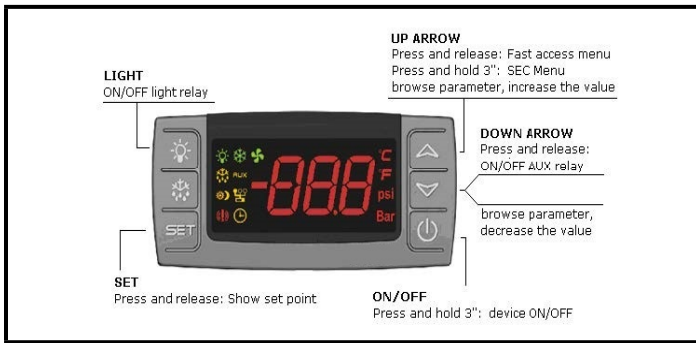

Figure 3-1 - XM670 - XM679 Front Panel

3.1 Keys and Functions

Table 3-1 lists the keys that are found on the front panel of XM670-XM679 controllers and the function of each:

Table 3-1 - XM670/XM679 Front Panel Keys and Functions

Key	Function
SET	Press to display the target setpoint, to select a parameter in programming mode, or to confirm an operation. Pressing this key for three (3) seconds while the minimum or maximum temperature is displayed will erase the temperature currently displayed.
	Press this key to browse the parameter codes in programming mode or increases the displayed value. Pressing this key for three (3) seconds will give you access to the Section menu.
	Press this key to access the fast access menu, browse the parameter codes in programming mode, decrease the displayed value, or activate or deactivate an auxiliary output.
	Starts a defrost when pressed for three (3) seconds.
	Switches the room light ON and OFF.
	Press for three (3) seconds to switch the device ON and OFF.
°C	Measurement unit
°F	Measurement unit
BAR	Measurement unit
PSI	Measurement unit

Table 3-1 - XM670/XM679 Front Panel Keys and Functions

Key Combinations	
	Locks/Unlocks the keyboard
SET +	Switches mode to programming mode
SET +	Exits the programming mode

3.2 Use of LEDS

Each LED function is described in Table 3-2:

Table 3-2 - LEDS

LED	Mode	Function
	ON	Compressor and valve regulation enabled. To see the valve opening percentage, enter the fast access menu.
	Flashing	Anti-short cycle delay enabled
	ON	Defrost enabled
	Flashing	Drip time in progress
	ON	An alarm is occurring
	ON	Energy saving enabled
	ON	Fans enabled (fans are running)
	Flashing	Door opened or delay after defrost
AUX	ON	Auxiliary relay ON
°C/°F/Bar/PSI	ON	Measurement unit
	Flashing	Programming phase
	ON	The controller is working in ALL mode
	Flashing	The controller is working in remote virtual display mode
	Flashing	During the CLOCK modification (if clock is present)

3.3 How to Enter the Fast Access Menu

1. Press and release the **UP** button.
2. The First Label will be displayed. Press the **UP** or **DOWN** button to navigate the menu.

3.4 How to See the MAX and MIN Temperature Recorded

1. Press and release the **UP** button.
2. The First Label will be displayed. Press the **UP** or **DOWN** button to navigate the menu. Search the **L^t** label and press **SET** to see minimum temperature; search the **H^t** label and press **SET** to see maximum temperature.

3.5 How to See and Modify the Setpoint

1. Press the **SET** button for three (3) seconds to show the setpoint value.
2. The measurement unit starts blinking.
3. To change the setpoint value, press the **UP** or **DOWN** button for 10 seconds.
4. To store the new setpoint value, press the **SET** key again or wait 10 seconds.

3.6 How to Start a Manual Defrost



Press the **DEF** key for more than three (3) seconds to start a manual defrost.

3.7 How to Enter the Parameters List PR1

To enter the parameter list in **Pr1** (user accessible parameters):

1. Enter the programming mode by pressing the **SET** and **DOWN** buttons for a few seconds (wait for the measurement unit to start blinking).
2. The controller will show the first parameter present in **Pr1**.

3.8 How to Enter the Parameters List PR2

To access the parameter list in **Pr2**:

1. Enter the **Pr1** level. Follow the steps in **Section 3.7, How to Enter the Parameters List PR1**.
2. Select **Pr2** parameter and press the **SET** key.
3. The **PAS** flashing message will display, followed shortly by "0--" with a flashing zero.
4. Use the **UP** or **DOWN** button to input the security code in the flashing digit. Confirm the security code by pressing **SET**. The security code is **321**.
5. If the security code is correct, the access to **Pr2** is enabled by pressing **SET** on the last digit.

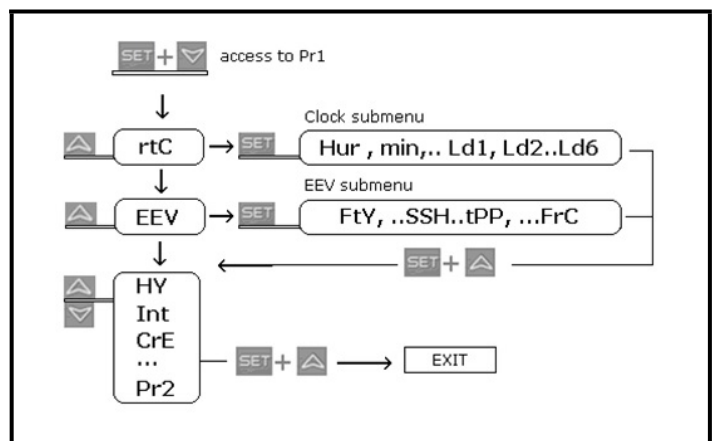

Figure 3-2 - Parameters List 2

Another way to enter the programming mode is by pressing the **SET** and **DOWN** buttons for 30 seconds immediately after switching the controller ON.

NOTE

Each parameter in **Pr2** can be removed or put into **Pr1** (user level) by pressing **SET + DOWN** buttons. When a parameter is present in **Pr1**, the Alarm LED will be display.

3.9 How to Assign a MODBUS Address

1. To enter the programming mode, press and hold the **SET** and **DOWN** buttons together until the temperature measurements start blinking.
2. Scroll through the parameters using the **UP** or **DOWN** button until **Adr** is displayed.
3. Press and hold **SET** to select **Adr**.
4. Use the arrow keys to choose the address number of the device.
5. Press and hold **SET** again to select the desired number and save.
6. To exit, press the **SET** and **UP** arrow keys together.

3.10 How to Change the Parameter Value

1. Enter the programming mode.
2. Select the required parameter using the **UP** or **DOWN** button.
3. Press the **SET** key to display the parameter value (measurement unit starts blinking).
4. Use the **UP** or **DOWN** button to change the value.
5. Press **SET** to store the new value and move to the next parameter.
6. To exit, press **SET + UP** keys or wait 15 seconds without pressing a key.

NOTE

The set value is stored even when the time-out expires and ends the procedure.

3.11 ON/OFF Function



By pressing the **ON/OFF** key, the controller shows OFF. During the OFF status, all the relays are switched OFF and the regulations are stopped; if a monitoring system is connected, it does not record the controller data and alarms.

NOTE

During the OFF status, the Light and **AUX** buttons are active.

4 Fast Access Menu

This menu contains the lists probes and some values that are automatically evacuated by the board, such as the superheat and the percentage of valve opening. The values below stands for:

- **nP** or **noP** - probe not present or value not evacuate
- **Err** - value out of range, probe damaged, not connected or incorrectly configured

Table 4-1 - Fast Access Menu

FAST ACCESS MENU		
HM	Fast Access Menu to Clock Settings	(If present)
An	Fast Access to Analog Output Reading	(If present)
SH	Superheat	Shows the actual superheat value (Only XM679)
oPP	Valve opening percentage	Shows the actual opening percentage of the valve (Only XM679)
dP1	Probe 1 value displaying	Shows the temperature measured by probe 1
dP2	Probe 2 value displaying	Shows the temperature measured by probe 2
dP3	Probe 3 value displaying	Shows the temperature measured by probe 3
dP4	Probe 4 value displaying	Shows the temperature measured by probe 4
dP5	Probe 5 value displaying	Shows the temperature measured by probe 5
dP6	Probe 6 value displaying	Shows the temperature measured by probe 6
dPP	Pressure probe value	Shows the value of pressure measured by pressure transducer (Only XM679)
rPP	Remote pressure probe value	Shows the value of pressure received by remote pressure probe connected to other XM600 device (Only XM679)
L^t	Minimum measured temperature	Shows the minimum temperature read by the regulation probe
H^t	Maximum measured temperature	Shows the maximum temperature read by the regulation probe
dPr	Virtual regulation probe value	Shows the value measured by the virtual regulation probe
dPd	Virtual defrost probe value	Shows the value measured by the virtual defrost probe
dPF	Virtual fans probe value	Shows the value measured by virtual fan probe
rSE	Real setpoint	Shows the setpoint used during the energy saving cycle or during the continuous cycle

5 Section Menu

This menu allows the user to access to a particular feature of the XM series related to the LAN (Local Area Network) of controllers. Depending on the programming of this menu, a single keyboard can control either the module of the local section of the LAN or ALL. The possibilities are: LOC: the keyboard controls and display the value, the status, and the alarms of the local section of the LAN; and ALL: the command given by the keyboard are effective on all the sections of the LAN.

1. Press the UP key for more than three (3) seconds.
2. The label corresponding to the section controlled by the keyboard will be displayed.
3. Using the **UP** or **DOWN** key, select the section you want to control.
4. Press the **SET** key to confirm and exit.

5.1 To Set Energy Saving Times

Table 5-1 - Energy Saving Times Parameters

ILE	Energy Saving cycle start during workdays	(0 to 23 h 50 min) During the Energy Saving cycle, the setpoint is increased by the value in HES so that the operation setpoint is SET + HES.
dLE	Energy Saving cycle length during workdays	(0 to 24 h 00 min) Sets the duration of the Energy Saving cycle on workdays.
ISE	Energy Saving cycle start on holidays	(0 to 23h 50 min)
dSE	Energy Saving cycle length on holidays	(0 o 24h 00 min)
HES	Temperature increase during the Energy Saving cycle	(-54 to 54°F/ -30 to 30°C) Sets the increasing value of the setpoint during the Energy Saving cycle.

5.2 To Set Timed Defrost Parameters

Table 5-2 - Timed Defrost Parameters

Ld1 to Ld6	Workday defrost start	(0 to 23h 50 min) These parameters set the beginning of the eight programmable defrost cycles during workdays. For example, when Ld2=12.4, the second defrost starts at 12.40 during workdays.
Sd1 to Sd6	Holiday defrost start	(0 to 23h 50 min) These parameters set the beginning of the eight programmable defrost cycles during holidays. For example, when Sd2=3.4, the second defrost starts at 3.40 on holidays.

NOTE

To disable a defrost cycle, set it to nu (not used). For example, if Ld6=nu, the sixth defrost cycle is disabled.

6 *Electronic Expansion Valve Menu (For Model XM679 Only)*

1. Enter the programming mode by pressing the **SET** and **DOWN** buttons for a few seconds (measurement unit starts blinking).
2. Press the **UP** or **DOWN** key until the controller displays the EEU label.
3. Press **SET**. You are now in EEV function menu.

7 Controlling Loads

7.1 Solenoid Valve

The regulation is performed based on the temperature measured by the thermostat probe that can be a physical probe or a virtual probe obtained by a weighted average between the two probes (see **Section 8, Parameters List**) with a positive differential from the setpoint. If the temperature increases and reaches setpoint plus the differential, the solenoid valve is opened and then it is closed when the temperature reaches the setpoint value again.

In case of fault in the thermostat probe, the opening and closing time of the solenoid valve are configured by **Con** and **CoF** parameters.

7.2 Standards Regulation and Continuous Regulation

The regulation can be performed in two ways:

- Standard regulation is reaching the best superheat via a classic temperature regulation obtained using hysteresis.
- Continuous regulation permits the use of the valve to realize a high performance temperature regulation with a good factor of superheat precision. *This only can be used only in centralized plants and it is available only with electronic expansion valve by selecting the **CrE=Y** parameter.*

In any case, the regulation is performed via the PI regulator that gives the opening percentage to the valve via PWM modulation explained as follows: Opening Percentage is obtained from the average of the Opening Time with respect to the **CyP** time period (see **Figure 7-1**).

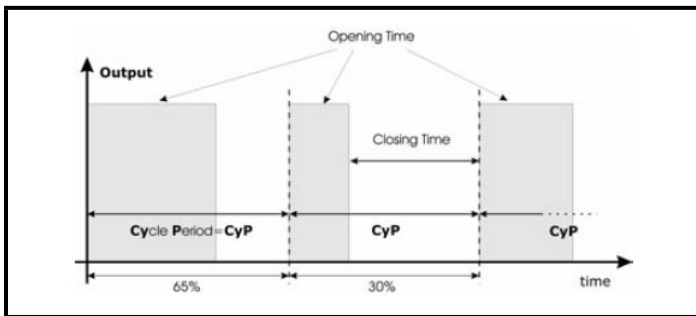

Figure 7-1 - Regulation via PI Regulator

Opening percentage is the percentage of the cycle period where the valve is open. For example, if **CyP=6s** (standard value) and the valve is opened at **50%**, this means that the valve is opened for three (3) seconds during the cycle period.

7.2.1 First Kind of Regulation: Standard Regulation

In this case, the **Hy** parameter is the differential for the standard ON/OFF regulation. In this case, the **int** parameter is neglected. The regulation follows the diagram shown in **Figure 7-2**:

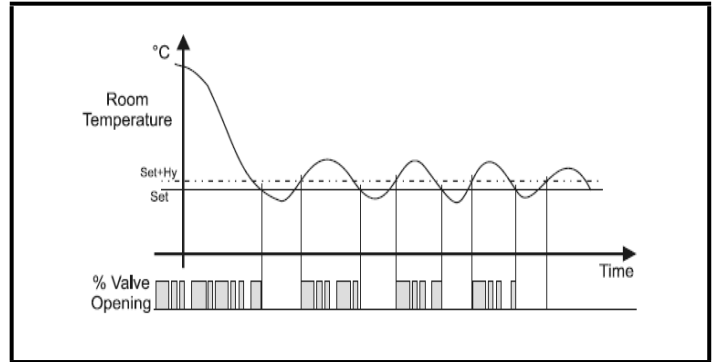

Figure 7-2 - First Kind of Regulation

7.2.2 Second Kind of Regulation: Continuous Regulation (For Model XM679 Only)

In this case, the **Hy** parameter is the proportional band of PI in charge of room temperature regulation. It is advisable to use at least **Hy=10°F/ 5.0°C**.

The **int** parameter is the integral time of the same PI regulator. Increasing the **int** parameter will cause the PI regulator to react more slowly, and is true vice versa. To disable the integral part of regulation, set **int=0**.

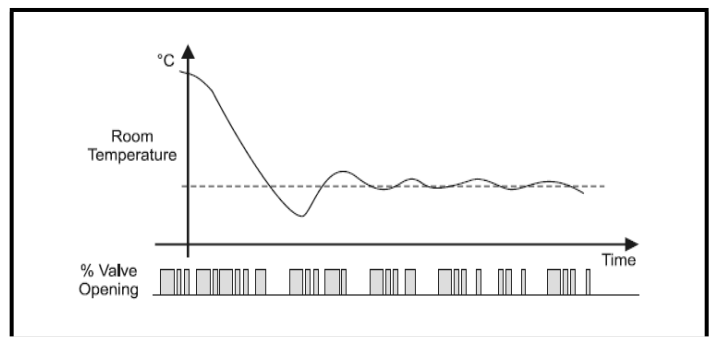

Figure 7-3 - Second Kind of Regulation

7.3 Defrost

7.3.1 Defrost starting

In any case, the device checks the temperature that is read by the configured defrost probe before starting defrost procedure. After that:

- Starting defrost cycles can be operated locally (manual activation by means of the keyboard or digital input or end of interval time) or the command can come from the Master defrost unit of the LAN. In this case, the controller will operate the defrost cycle following the parameters it has programmed, but at the end of the drip time it will wait until all the other LAN controllers finish their defrost cycle before the normal regulation of the temperature is restarted according to the **dEM** parameter.
- Every time any of the LAN controllers begin a defrost cycle, it issues the command to the network making all the other controllers start their own cycle. This allows a perfect synchronization of the defrost in the whole multiplexed cabinet according to **LMd** parameter.
- By selecting the **dPA** and **dPb** probes and changing the **dtP** and **ddP** parameters, defrost can be started when the difference between the **dPA** and **dPb** probes is lower than **dtP** for all **ddP** time. This is useful to start defrost when a low thermal exchange is detected. If **ddP=0**, this function is disabled.

7.3.2 Defrost Ending

- If **dPA** and **dPb** are present and **d2P=y**, the controller stops the defrost procedure when **dPA** is higher than the **dtE** temperature and **dPb** is higher than the **dtS** temperature.

At the end of defrost, the drip time is controlled through the **Fdt** parameter.

7.4 Fans

7.4.1 Control With Relay

The fan control mode is selected by means of the **FnC** parameter:

- C-n** = running with the solenoid valve, OFF during defrost
- C-y** = running with the solenoid valve, ON during defrost
- O-n** = continuous mode, OFF during defrost
- O-y** = continuous mode, ON during defrost

An additional parameter **FSt** provides the setting of temperature, detected by the evaporator probe, above which the fans are always OFF. This ensures that air is circulated only if the temperature is lower than set in **FSt**.

7.4.2 Control With Analog Output (If Present)

The modulating output (**trA=rEG**) works in a proportional manner (excluding the first **AMt** seconds where the fans speed is the maximum). The regulation setpoint is relative to the regulation setpoint and is indicated by the parameter **ASr**, the proportional band is always located above the **SET+ASr** value and its value is **PbA**. The fans are at minimum speed (**AMi**) when the temperature read by the fan probe is **SET+ASr** and the fans are at maximum speed (**AMA**) when the temperature is **SET+ASr+PbA**.

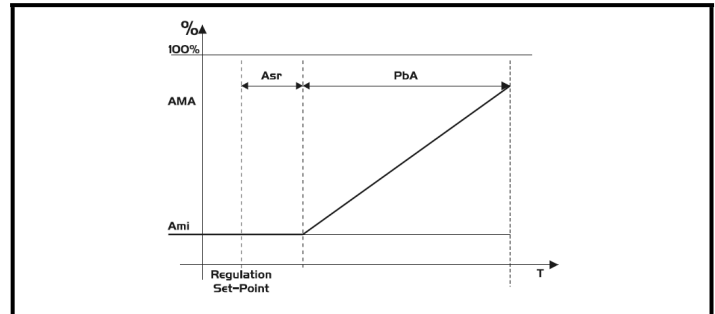

Figure 7-4 - Control with Analog Output

7.5 Anti-Sweat Heaters (If Present)

This control is performed when **trA=AC**. In this case, there are two ways to control the anti-sweat heaters:

- Without real dewpoint information: in this case, the default value for dewpoint is used (**SdP** parameter).
- Dewpoint received from the XWEB5000 system: the **SdP** parameter is overwritten when the valid value for dewpoint is received from XWEB.

The P4 probe is used to perform the regulation and it should be placed on the showcase glass. In case of P4 error or if P4 is absent, the output is at **AMA** value for the **AMt** time then the output is at 0 value for the time **255-AMt** time performing a simple PWM modulation.

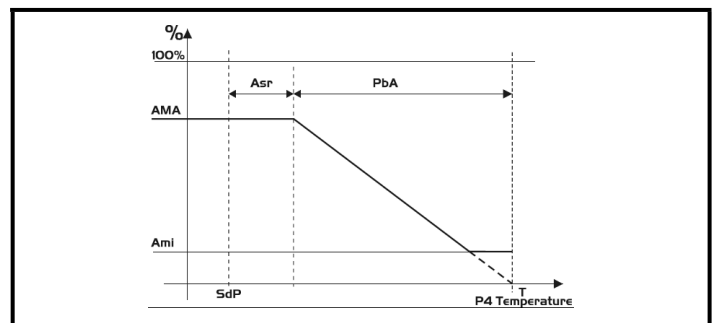

Figure 7-5 - Anti-Sweat Heaters

7.6 Auxiliary Output

The auxiliary output is switched ON and OFF by means of the corresponding digital input or by pressing and releasing the **DOWN** key.

8 Parameters List

Table 8-1 - XM670 to XM679 Parameters List

REGULATION	
EEU	Access to EEV sub-menu (only XM679)
Hy	Differential: (1 to 45°F; 0.1 to 25.5°C) This is the intervention differential for setpoint, this value is always positive. Solenoid valve Cut IN is Setpoint Plus Differential (Hy). Solenoid valve Cut OUT is when the temperature reaches the setpoint.
Int	Integral time for room temperature regulation (Only XM679): (0 to 255 s) This is the integral time for room temperature PI regulator. 0= no integral action.
CrE	Continuous regulation activation (Only XM679): (n to Y) n= standard regulation; Y= continuous regulation. Use it only in centralized plants.
LS	Minimum setpoint limit: (-67°F to SET; -55.0°C to SET) Sets the minimum acceptable value for the setpoint.
US	Maximum setpoint limit: (SET to 302°F; SET to 150°C) Set the maximum acceptable value for setpoint.
Ods	Outputs activation delay at start up: (0 to 255 min) This function is enabled at the initial start up of the device and inhibits any output activation for the time set in the parameter. (AUX and Light can work)
AC	Anti-short cycle delay: (0 to 60 min) The interval between the solenoid valve stop and the following restart.
CcT	Compressor ON time during continuous cycle: (0.0 to 24.0h; resolution 10min) Allows to set the length of the continuous cycle: compressor stays on without interruption for the CcT time. Can be used, for instance, when the room is filled with new products.
CCS	Setpoint for continuous cycle: (-67 to 302°F / -55 to 150°C) it sets the setpoint used during the continuous cycle.
Con	Solenoid valve ON time with faulty probe: (0 to 255 min) The time during which the solenoid valve is active in case of faulty thermostat probe. With COn=0 solenoid valve is always OFF.
CoF	Solenoid valve OFF time with faulty probe: (0 to 255 min) time during which the solenoid valve is off in case of faulty thermostat probe. With COF=0 solenoid valve is always active.
DISPLAY	
CF	Temperature measurement unit: °C = Celsius; °F = Fahrenheit. CAUTION! When the measurement unit is changed the parameters with temperature values have to be checked.
PrU	Pressure mode: (rEL or AbS) defines the mode to use the pressure. CAUTION! the setting of PrU is used for all the pressure parameters. If PrU = rEL all pressure parameters are in relative pressure unit, if PrU = AbS all pressure parameters are in absolute pressure unit. (Only XM679)
PMU	Pressure measurement unit: (bAr - PSI - MPA) it selects the pressure measurement units. MPA= the value of pressure measured by kPA* 10. (Only XM679)
PMd	Way of displaying pressure: (tEM - PrE) it permits showing the value measured by pressure probe with tEM= temperature or by PrE= pressure (Only XM679)
rES	Resolution (for °C): (in = 1°C; dE = 0.1 °C) allows decimal point display
Lod	Device display: (nP; P1; P2, P3, P4, P5, P6, tEr, dEF) it selects which probe is displayed by the device. P1, P2, P3, P4, P5, P6, tEr= virtual probe for thermostat, dEF= virtual probe for defrost.
red	Remote display: (nP; P1; P2, P3, P4, P5, P6, tEr, dEF) it selects which probe is displayed by the X-REP. P1, P2, P3, P4, P5, P6, tEr= virtual probe for thermostat, dEF= virtual probe for defrost.
dLy	Display delay: (0 to 24.0 m; resolution 10s) when the temperature increases, the display is updated of 1 °F/1°C after this time.
rPA	Regulation probe A: (nP; P1; P2, P3, P4, P5) first probe used to regulate room temperature. If rPA = nP the regulation is performed with real value of rPb.

Table 8-1 - XM670 to XM679 Parameters List

rPb	Regulation probe B: (nP; P1; P2, P3, P4, P5) second probe used to regulate room temperature. If rPb = nP the regulation is performed with real value of rPA
rPE	Regulation virtual probe percentage: (0 to 100%) it defines the percentage of the rPA respect to rPb. The value used to regulate room temperature is obtained by: $value_for_room = (rPA * rPE + rPb * (100 - rPE)) / 100$
ELECTRONIC EXPANSION VALVE SUBMENU (Only XM679)	
FtY	Kind of gas (R22, 134, 404, 407, 410, 507, CO2): Type of gas used by plant. Fundamental parameter for correct functioning of all system.
SSH	Superheat setpoint: [1°F to 45°F] [0.1°C to 25.5°C] This is the value used to regulate superheat.
CyP	Cycle Period: (1 to 15s) Allows to set cycle time
Pb	Proportional band: (1 to 108°F / 0.1 to 60.0) PI proportional band
rS	Band Offset: (-21 to 21°F / -12.0 to 12.0°C) PI band offset
inC	Integration time: (0 to 255s) PI integration time
PEO	Probe Error opening percentage: (0 to 100%) if a temporary probe error occurs, valve opening percentage is PEO until PED time is elapsed.
PEd	Probe Error delay before stopping regulation: (0 to 239 sec. - On = unlimited) if probe error duration is bigger than PEd then valve totally closes. Pf message displays. If PEd = On valve opening is PEO until probe error finishes.
OPE	Start opening Percentage: (0 to 100%) Valve opening percentage when start function is active. This phase duration is SFd time.
SFd	Start Function duration: (0.0 to 42.0 min: resolution 10s) Sets start function duration and post-defrost duration. During this phase the alarms are neglected.
OPd	Opening Percentage after defrost phase: (0 to 100%) Opening valve percentage when after defrost function is active. This phase duration is Pdd time.
Pdd	Post Defrost Function duration: (0.0 to 42.0 min: resolution 10s) Sets start function duration and post-defrost duration. During this phase the alarms are neglected.
MnF	Maximum opening percentage at normal Functioning: (0 to 100%) during regulation it sets the maximum valve opening percentage.
dCL	Delay before stopping valve regulation: (0 to 255s) When the cooling request goes off, the electronic valve regulation can go on for the dCL time in order to prevent uncontrolled superheat variation.
Fot	Forced opening percentage: (0 to 100% - nu) it permits to force the valve opening to the specified value. This value overwrites the value calculated by PID algorithm. CAUTION! To obtain the correct superheat regulation you have to set Fot = nu.
tPP	Type of Pressure Transducer: (PP - LAN) it sets type of pressure transducer to use: PP= 4 to 20mA pressure transducer or ratiometric transducer 0 to 5V depending on P5C parameter, LAN= the pressure signal arrives from another XM600. Referred to Pb5
PA4	Probe value At 4mA or At 0V: (-1.0 to P20 bar / -14 to PSI / -10 to P20 kPA*10) pressure value measured by probe at 4mA or at 0V (related to PrM parameter) Referred to Pb5
P20	Probe value 20mA or At 5V: (PA4 to 50.0 bar / 725 psi / 500 kPA*10) pressure value measured by probe at 20mA or at 5V (related to PrM parameter) Referred to Pb5
LPL	Lower Pressure Limit for superheat regulation: (PA4 to P20 bar / psi / kPA*10) when suction pressure comes down to LPL the regulation is performed with a LPL fixed value for pressure, when pressure comes back to LPL the normal pressure value is used. (related to PrM parameter)
MOP	Maximum Operating Pressure threshold: (PA4 to P20 bar / psi / kPA*10) if suction pressure exceeds maximum operating pressure value, device signals situation with MOP alarm. (related to PrM parameter)
LOP	Lowest Operating Pressure threshold: (PA4 to P20 bar / psi / kPA*10) If the suction pressure comes down to this value, a low pressure alarm is signaled with LOP alarm. (related to PrM parameter)

Table 8-1 - XM670 to XM679 Parameters List

dML	Delta MOP-LOP: (0 to 100%) When a MOP alarm occurs, the valve will close of the dML percentage every cycle period until MOP alarm is active. When LOP occurs, the valve will open of the dML percentage every cycle period until LOP alarm is active.
MSH	Maximum Superheat alarm: (LSH to 144°F / LSH to 80.0°C) When the superheat exceeds this value, a high superheat alarm is signaled after interval SHd.
LSH	Lowest Superheat alarm: (0 to MSH °F / 0.0 to MSH °C) When the superheat goes down to this value, a low superheat alarm is signaled after interval SHd.
SHy	Superheat alarm Hysteresis: (1 to 45°F / 0.1 to 25.5°C) Hysteresis for superheat alarm deactivation.
SHd	Superheat alarm activation delay: (0.0 to 42.0 min: resolution 10s) When a superheat alarm occurs, the time SHd have to pass before signaling the alarm.
FrC	Fast-recovery Constant: (0 to 100 s) permits to increase integral time when SH is below the setpoint. If FrC=0 fast recovery function is disabled.

DEFROST

dPA	Defrost Probe A: (nP; P1; P2, P3, P4, P5) first probe used for defrost. If rPA = nP the regulation is performed with real value of dPb.
dPb	Defrost Probe B: (nP; P1; P2, P3, P4, P5) second probe used for defrost. If rPB = nP the regulation is performed with real value of dPA.
dPE	Defrost virtual probe percentage: (0 to 100%) it defines the percentage of the dPA respect to dPb. The value used to regulate room temperature is obtained by: $value_for_defrost = (dPA * dPE + dPb * (100 - dPE)) / 100$.
tdF	Defrost type: (EL - in) EL = electrical heater; in = hot gas.
EdF	Defrost mode: (in) In= interval defrost activation with idf.
Srt	Heater setpoint during defrost: (-67 to 302°F; -55.0 to 150.0°C) if tdF=EL during the defrost the defrost relay perform an ON/OFF regulation with Srt as setpoint.
Hyr	Differential for heater: (1°F to 45°F, 0.1°C to 25.5°C) the differential for heater
tod	Time out for heater: 0 to 255 (min.) if the defrost probe temperature is bigger than Srt for all tod time the defrost ends although the defrost probe temperature is lower than dtE or dtS. It permits to reduce defrost duration.
dtP	Minimum temperature difference to start defrost: [1°F to 90°F] [0.1°C to 50.0°C] if the difference between the two defrost probes stays lower than dtP for all ddP time the defrost is activated.
ddP	Delay before starting defrost (related to dtP): (0 to 60 min) delay related to dtP.
d2P	Defrost with two probes: (n - Y) n= only the dPA probe is used to defrost management; Y= defrost is managed with dPA probe and dPb probe. Defrost can performed only if both probe value are lower than dtE for dPA probe and dtS for dPb probe.
dtE	Defrost termination temperature (Probe A): (-67 to 122°F; -55.0 to 50.0°C) (Enabled only when the evaporator probe is present) sets the temperature measured by the evaporator probe dPA which causes the end of defrost.
dtS	Defrost termination temperature (Probe B): (-67 to 122°F; -55.0 to 50.0°C) (Enabled only when the evaporator probe is present) sets the temperature measured by the evaporator probe dPb which causes the end of defrost.
IdF	Interval between defrosts: (0 to 120h) Determines the time interval between the beginning of two defrost cycles.
MdF	Maximum duration of defrost: (0 to 255 min) When dPA and dPb aren't present, it sets the defrost duration, otherwise it sets the maximum duration for defrost.
dSd	Start defrost delay: (0 to 255 min) This is useful when different defrost start times are necessary to avoid overloading the plant.
dFd	Display during defrost: rt = real temperature; it = temperature reading at the defrost start; Set = setpoint; dEF = "dEF" label.
dAd	Defrost display time out: (0 to 255 min) Sets the maximum time between the end of defrost and the restarting of the real room temperature display.
Fdt	Drain down time: (0 to 255 min.) time interval between reaching defrost termination temperature and the restoring of the control's normal operation. This time allows the evaporator to eliminate water drops that might have formed due to defrost.

Table 8-1 - XM670 to XM679 Parameters List

dPo	First defrost after start-up: y = Immediately; n = after the ldf time
dAF	Defrost delay after continuous cycle: (0 to 23.5h) time interval between the end of the fast freezing cycle and the following defrost related to it.
FAN	
FPA	Fan probe A: (nP; P1; P2, P3, P4, P5) first probe used for fan. If FPA = nP the regulation is performed with real value of FPB.
FPB	Fan probe B: (nP; P1; P2, P3, P4, P5) second probe used for defrost. If FPB = nP the regulation is performed with real value of FPB.
FPE	Fan virtual probe percentage: (0 to 100%) Defines the percentage of the FPA with respect to FPb. The value used to regulate room temperature is obtained by: $value_for_defrost = (FPA * FPE + FPb * (100 - FPE)) / 100$.
FnC	Fan operating mode: C-n = running with the solenoid valve, OFF during the defrost; C-y = running with the solenoid valve, ON during the defrost; O-n = continuous mode, OFF during the defrost; O-y = continuous mode, ON during the defrost.
Fnd	Fan delay after defrost: (0 to 255 min) The time interval between the defrost end and evaporator fans start.
Fct	Temperature differential avoiding short cycles of fans (0°F to 90°F; 0.0°C to 50.0°C) If the difference of temperature between the evaporator and the room probes is more than the value of the Fct parameter, the fans are switched on.
FSt	Fan stop temperature: (-58 to 230°F; -50 to 110°C) setting of temperature, detected by evaporator probe, above which the fan is always OFF.
FHy	Differential to restart fan: (1°F to 45°F) (0.1°C to 25.5°C) when stopped, fan restarts when fan probe reaches FSt-FHy temperature.
Fod	Fan activation time after defrost: (0 to 255 min.) it forces fan activation for indicated time.
Fon	Fan ON time: (0 to 15 min) with Fnc = C_n or C_y, (fan activated in parallel with compressor). Sets the evaporator fan ON cycling time when the compressor is off. With Fon =0 and FoF =0 the fan are always off, with Fon=0 and FoF =0 the fan are always off.
FoF	Fan OFF time: (0 to 15 min) with Fnc = C_n or C_y, (fan activated in parallel with compressor). Sets the evaporator fan off cycling time when the compressor is off. With Fon =0 and FoF =0 the fans are always off, with Fon=0 and FoF =0 the fans are always off.
MODULATING OUTPUT (AnOUT) if Present	
trA	Kind of regulation with PWM output: (UAL - rEG - AC) it selects the functioning for the PWM output if CoM is not equal to OA7. UAL= the output is at FSA value; rEG= the output is regulated with fan algorithm described in fan section; AC= anti-sweat heaters control (require the XWEB5000 system).
SOA	Fixed value for analog output: (0 to 100%) value for the output if trA = UAL.
SdP	Default value for Dew point: (-67 to 122°F; -55.0 to 50.0°C) default value of dew point used when there is no supervising system (XWEB5000). Used only when trA=AC.
ASr	Dew-point offset (trA=AC) / Differential for modulating fan regulation (trA=rEG): (-45°F to 45°F) (-25.5°C to 25.5°C).
PbA	Differential for anti-sweat heaters: (1°F to 45°F) (0.1°C to 25.5°C)
AMi	Minimum value for analog output: (0 to AMA)
AMA	Maximum value for analog output: (Ami to 100)
AMt	Anti-sweat heaters cycle period (trA=AC)/ Time with fan at maximum speed (trA=rEG): (0 to 255 s) when the fan starts, during this time the fan is at maximum speed.

Table 8-1 - XM670 to XM679 Parameters List

ALARMS	
rAL	Probe for temperature alarm: (nP - P1 - P2 - P3 - P4 - P5 - tEr) Selects the probe used to signal alarm temperature.
ALC	Temperature alarm configuration: rE = High and Low alarms related to Setpoint; Ab = High and low alarms related to the absolute temperature.
ALU	High temperature alarm setting: (ALC= rE, 0 to 90°F or 50°C / ALC= Ab, ALL to 302°F or 150°C) when this temperature is reached and after the ALd delay time the HA alarm is enabled.
ALL	Low temperature alarm setting: (ALC = rE, 0 to 90°F or 50 °C / ALC = Ab, - 67°F or - 55°C to ALU) when this temperature is reached and after the ALd delay time, the LA alarm is enabled.
AHy	Differential for temperature alarm: (1°F to 45°F / 0.1°C to 25.5°C) Intervention differential for recovery of temperature alarm.
ALd	Temperature alarm delay: (0 to 255 min) The time interval between the detection of an alarm condition and the corresponding alarm signaling.
dLU	High temperature alarm (defrost probe): (ALC= rE, 0 to 90°F or 50°C / ALC= Ab, ALL to 302°F or 150°C) When this temperature is reached and after the ddA delay time, the HAd alarm is enabled.
dLL	Low temperature alarm (defrost probe): (ALC = rE, 0 to 90°F or 50 °C / ALC = Ab, - 67°F or - 55°C to ALU) when this temperature is reached and after the ALd delay time, the LAd alarm is enabled.
dAH	Differential for temperature alarm (defrost probe): (1°F to 45°F / 0.1°C to 25.5°C) Intervention differential for recovery of temperature alarm.
ddA	Temperature alarm delay (defrost probe): (0 to 255 min) time interval between the detection of an alarm condition and the corresponding alarm signaling.
FLU	High temperature alarm (defrost probe): (ALC= rE, 0 to 90°F or 50°C / ALC= Ab, ALL to 302°F or 150°C) when this temperature is reached and after the FAd delay time the HAF alarm is enabled.
FLL	Low temperature alarm (defrost probe): (ALC = rE, 0 to 90°F or 50°C / ALC = Ab, - 67°F or - 55°C to ALU) when this temperature is reached and after the FAd delay time, the LAF alarm is enabled.
FAH	Differential for temperature alarm (defrost probe): (1°F to 45°F / 0.1°C to 25.5°C) Intervention differential for recovery of temperature alarm.
FAd	Temperature alarm delay (defrost probe): (0 to 255 min) time interval between the detection of an alarm condition and the corresponding alarm signaling.
dAO	Delay of temperature alarm at start-up: (0min to 23h 50min) The time interval between the detection of the temperature alarm condition after the device power on and the alarm signaling.
EdA	Alarm delay at the end of defrost: (0 to 255 min) Time interval between the detection of the temperature alarm condition at the end of defrost and the alarm signaling.
dot	Temperature alarm exclusion after door open
Sti	Stop regulation interval (Only XM679): (0.0 to 24.0 hours: tens of minutes) After regulating continuously for Sti time, the valve closes for Std time to prevent ice from forming.
Std	Stop duration (Only XM679): (0 to 60 min.) Defines the stop regulation time after Sti. During this stop display shows StP message.
OA6	Sixth relay configuration (CPr-dEF-Fan-ALr-LiG-AUS-db-OnF): CPr= relay works as a compressor or solenoid valve relay; dEF= relay works as defrost relay; Fan= relay works as a Fan relay; ALr= activation with alarm conditions; LiG= light activation; AUS= auxiliary relay, it can be switched ON/OFF also by key; db= deadband regulation (not compatible with CrE = y); OnF= ON/OFF functioning.

Table 8-1 - XM670 to XM679 Parameters List

OPTIONAL OUTPUT (AnOUT) If Present	
OA7	Modulating output configuration (if CoM=OA7): (CPr - dEF - FAn - ALr - LiG - AUS - db) it selects the functioning of the modulating output in case of CoM=OA7: CPr= compressor; dEF= defrost; FAn= Fan; ALr= Alarm; LiG= Light; AUS= auxiliary; db= neutral zone (not available with CrE=Y)
CoM	Type of functioning modulating output: For models with PWM / O.C. output -> PM5= PWM 50Hz; PM6= PWM 60Hz; OA7= two state, it can be used as an open collector output For models with 4 to 20mA / 0 to 10V output -> Cur= 4 to 20mA current output; tEn= 0 to 10V voltage output
AOP	Alarm relay polarity: cL= normally closed; oP= normally opened
iAU	Auxiliary output is unrelated to ON/OFF device status: n= if the device is switched off also the auxiliary output is switched off; Y= the auxiliary output state is unrelated to the ON/OFF device status.
i1P	Digital input 1 polarity: (cL - oP) CL: the digital input is activated by closing the contact; OP: the digital input is activated by opening the contact.
i1F	Digital input 1 function: (EAL - bAL - PAL - dor - dEF - AUS - LiG - OnF - Htr - FHU - ES - Hdy) EAL= external alarm; bAL= serious external alarm; PAL= pressure switch activation; dor= door open; dEF= defrost activation; AUS= auxiliary activation; LiG= light activation; OnF= switch on/off the device; Htr= change type of action; FHU= not used; ES= activate energy saving; Hdy= activate holiday function
d1d	Time interval/delay for digital input alarm: (0 to 255 min.) Time interval to calculate the number of the pressure switch activation when i1F=PAL. If i1F=EAL or bAL (external alarms), "d1d" parameter defines the time delay between the detection and the successive signaling of the alarm. If i1F=dor this is the delay to activate door open alarm.
i2P	Digital input 2 polarity: (cL - oP) CL: the digital input is activated by closing the contact; OP: the digital input is activated by opening the contact.
i2F	Digital input 2 function: (EAL - bAL - PAL - dor - dEF - AUS - LiG - OnF - Htr - FHU - ES - Hdy) EAL= external alarm; bAL= serious external alarm; PAL= pressure switch activation; dor= door open; dEF= defrost activation; AUS= auxiliary activation; LiG= light activation; OnF= switch on/off the device; Htr= change type of action; FHU= not used; ES= activate energy saving; Hdy= activate holiday function
d2d	Time interval/delay for digital input alarm: (0 to 255 min.) Time interval to calculate the number of the pressure switch activation when i2F=PAL. If i2F=EAL or bAL (external alarms), "d2d" parameter defines the time delay between the detection and the successive signaling of the alarm. If i2F=dor this is the delay to activate door open alarm.
i3P	Digital input 3 polarity: (cL - oP) CL: the digital input is activated by closing the contact; OP: the digital input is activated by opening the contact.
i3F	Digital input 3 function: (EAL - bAL - PAL - dor - dEF - AUS - LiG - OnF - Htr - FHU - ES - Hdy) EAL= external alarm; bAL= serious external alarm; PAL= pressure switch activation; dor= door open; dEF= defrost activation; AUS= auxiliary activation; LiG= light activation; OnF= switch on/off the device; Htr= change type of action; FHU= not used; ES= activate energy saving; Hdy= activate holiday function
d3d	Time interval/delay for digital input alarm: (0 to 255 min.) Time interval to calculate the number of the pressure switch activation when i3F=PAL. If i3F=EAL or bAL (external alarms), "d3d" parameter defines the time delay between the detection and the successive signaling of the alarm. If i3F=dor this is the delay to activate door open alarm.
nPS	Pressure switch number: (0 to 15) Number of activation of the pressure switch, during the "d#d" interval, before signaling the alarm event (i2F= PAL). If the nPS activation in the did time is reached, switch off and on the device to restart normal regulation.
odc	Compressor and fan status when open door: no = normal; Fan = Fan OFF; CPr = Compressor OFF; F_C = Compressor and fan OFF.
rrd	Outputs restart after door open alarm.

Table 8-1 - XM670 to XM679 Parameters List

ENERGY SAVING	
ESP	Energy saving probe selection: (nP - P1 - P2 - P3 - P4 - P5 - tEr).
HES	Temperature increase during the Energy Saving cycle: (-54 to 54°F / -30 to 30°C) sets the increasing value of the setpoint during the Energy Saving cycle.
PEL	Energy saving activation when light is switched off: (n to Y) n= function disabled; Y= energy saving is activated when the light is switched off and vice versa.
LAN MANAGEMENT	
LMd	Defrost synchronization: y= the section send a command to start defrost to other controllers, n= the section don't send a global defrost command
dEM	Type of end defrost: n= the of the LAN defrost are independent; y= the end of the defrost are synchronized
LSP	L.A.N. set-point synchronization: y= the section set-point, when modified, is updated to the same value on all the other sections; n= the set-point value is modified only in the local section
LdS	L.A.N. display synchronization: y= the value displayed by the section is sent to all the other sections; n= the set-point value is modified only in the local section
LOF	L.A.N. On/Off synchronization this parameter states if the On/Off command of the section will act on all the other ones too: y= the On/Off command is sent to all the other sections; n= the On/Off command acts only in the local section
LLi	L.A.N. light synchronization this parameter states if the light command of the section will act on all the other ones too: y= the light command is sent to all the other sections; n= the light command acts only in the local section
LAU	L.A.N. AUX output synchronization this parameter states if the AUX command of the section will act on all the other ones too: y= the light command is sent to all the other sections; n= the light command acts only in the local section
LES	L.A.N. energy saving synchronization this parameter states if the energy saving command of the section will act on all the other ones too: y= the Energy Saving command is sent to all the other sections; n= the Energy Saving command acts only in the local section
Lsd	Remote probe display: this parameter states if the section has to display the local probe value or the value coming from another section: y= the displayed value is the one coming from another section (which has parameter LdS = y); n= the displayed value is the local probe one.
LPP	Remote pressure probe: n= the value of pressure probe is read from local probe; Y= the value of pressure probe is sent via LAN.
StM	Solenoid activation via LAN: n= not used; Y= a generic cooling requests from LAN activate the solenoid valve connected to compressor relay.
PROBE CONFIGURATION	
P1C	Probe 1 configuration: (nP - Ptc - ntc - PtM) nP= not present; PtC= Ptc; ntc= Ptc; PtM= Pt1000
Ot	Probe 1 calibration: (-21 to 21°F/ -12.0 to 12.0°C) allows to adjust possible offset of the thermostat probe.
P2C	Probe 2 configuration: (nP - Ptc - ntc - PtM) nP= not present; PtC= Ptc; ntc= Ptc; PtM= Pt1000
OE	Probe 2 calibration: (-21 to 21°F/ -12.0 to 12.0°C) allows to adjust possible offsets of the evaporator probe.
P3C	Probe 3 configuration: (nP - Ptc - ntc - PtM) nP= not present; PtC= Ptc; ntc= Ptc; PtM= Pt1000
o3	Probe 3 calibration: (-21 to 21°F/ -12.0 to 12.0°C) allows to adjust possible offset of the probe 3.
P4C	Probe 4 configuration: (nP - Ptc - ntc - PtM) nP= not present; PtC= Ptc; ntc= Ptc; PtM= Pt1000
o4	Probe 4 calibration: (-21 to 21°F/ -12.0 to 12.0°C) allows to adjust possible offset of the probe 4.
P5C	Probe 5 configuration: (nP - Ptc - ntc - PtM - 420 - 5Vr) nP= not present; PtM= Pt1000; 420= 4 to 20mA; 5Vr= 0 to 5V ratiometric; (Only XM679)
o5	Probe 5 calibration: (-21 to 21°F/ -12.0 to 12.0°C) allows to adjust possible offset of the probe 5. (Only XM679)

Table 8-1 - XM670 to XM679 Parameters List

P6C	Probe 6 configuration: (nP - Ptc - ntc - PtM) nP= not present; PtC= Ptc; ntc= Ptc; PtM= Pt1000; (Only XM679)
o6	Probe 6 calibration: (-21 to 21°F/ -12.0 to 12.0°C) allows to adjust possible offset of the probe 6. (Only XM679)
SERVICE - READ ONLY	
CLt	Cooling time percentage: it shows the effective cooling time calculated by XM600 during regulation
tMd	Time to next defrost: it shows time before the next defrost if interval defrost is selected
LSn	L.A.N. section number (1 to 5) Shows the number of sections available in the L.A.N.
Lan	L.A.N. serial address (1 to LSn) Identifies the device address inside local network of multiplexed cabinet controller.
Adr	RS485 serial address (1 to 247): Identifies the device address when connected to a MODBUS compatible monitoring system.
Rel	Release software: (read only) Software version of the microprocessor.
Ptb	Parameter table: (read only) it shows the original code of the DIXEL parameter map.
Pr2	Access to the protected parameter list (read only)

9 Digital Inputs

The XM600 series of controllers can support up to three (3) configurable digital inputs that are free of voltage contact (depending on the models). They are configurable via **i#F** parameter.

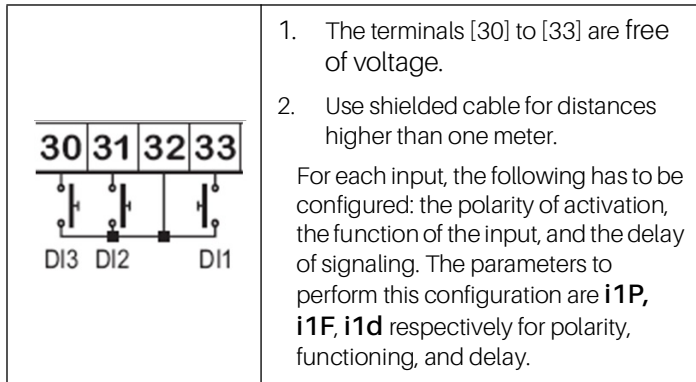

9.1 Generic Alarm (EAL)

As soon as the digital input is activated, the controller will wait for the **did** time delay before signaling the **EAL** alarm message. The outputs status don't change. The alarm will stop as soon as the digital input is deactivated.

9.2 Serious Alarm Mode (bAL)

When the digital input is activated, the controller will wait for the **did** time delay before signaling the **bAL** alarm message. The relay outputs are switched OFF. The alarm will stop as soon as the digital input is deactivated.

9.3 Pressure Switch (PAL)

If the pressure switch has reached the number of activation of the **nPS** parameter during the interval time set by the **d#d** parameter, the **CA** pressure alarm message will be displayed. The compressor and the regulation are stopped. When the digital input is ON the compressor is always OFF. If the nPS activation in the d#d time is reached, switch the controller OFF and ON to restart normal regulation.

9.4 Door Switch Input (dor)

This input signals the door status and the corresponding relay output status through the **odc** parameter: **no** = normal (any change); **Fan** = Fan OFF; **CPr** = Compressor OFF; **F_C** = Compressor and fan OFF. Since the door is opened, after the delay time set through parameter **d#d**, the door alarm is enabled, the display shows the message **dA**, and the regulation restarts after **rrd** time. The alarm stops as soon as the external digital input is disabled again. With the door open, the high and low temperature alarms are disabled.

9.5 Start Defrost (dEF)

A defrost will start if the right conditions exist. After the defrost is finished, normal regulation will restart only if the digital input is disabled; otherwise, the controller will wait until the **MdF** safety time is expired.

9.6 Relay Aux Actuation (AUS)

This function enables the auxiliary relay to be turned ON and OFF by using the digital input as external switch.

9.7 Relay Light Actuation (LiG)

This function enables the light relay to be turned ON and OFF by using the digital input as external switch.

9.8 Remote ON/OFF (OnF)

This function switches the controller ON and OFF.

9.9 Kind of Action (Htr)

This function enables the change in the kind of regulation: from cooling to heating and vice versa.

9.10 FHU (Not Used)

This function enables the change in the kind of regulation: from cooling to heating and vice versa.

9.11 Energy Saving Input (ES)

The Energy Saving function allows you to change the setpoint value as the result of the **SET+ HES** (parameter) sum. This function is enabled until the digital input is activated.

9.12 Configurable Input - Holiday Function (HDY)

In Holiday function, the Energy Saving and defrost cycles follow holiday times (**Sd1...Sd6**).

9.13 Digital Inputs Polarity

The digital inputs polarity depends on the **I#P** parameters: **CL** (the digital input is activated by closing the contact) and **OP** (the digital input is activated by opening the contact).

10 Installation and Mounting

The XM679 can operate without any user interface, but normal application is with the CX660 keyboard. The CX660 keyboard should be mounted on a vertical panel, in a 29 mm x 71 mm hole, and secured using the special bracket supplied.

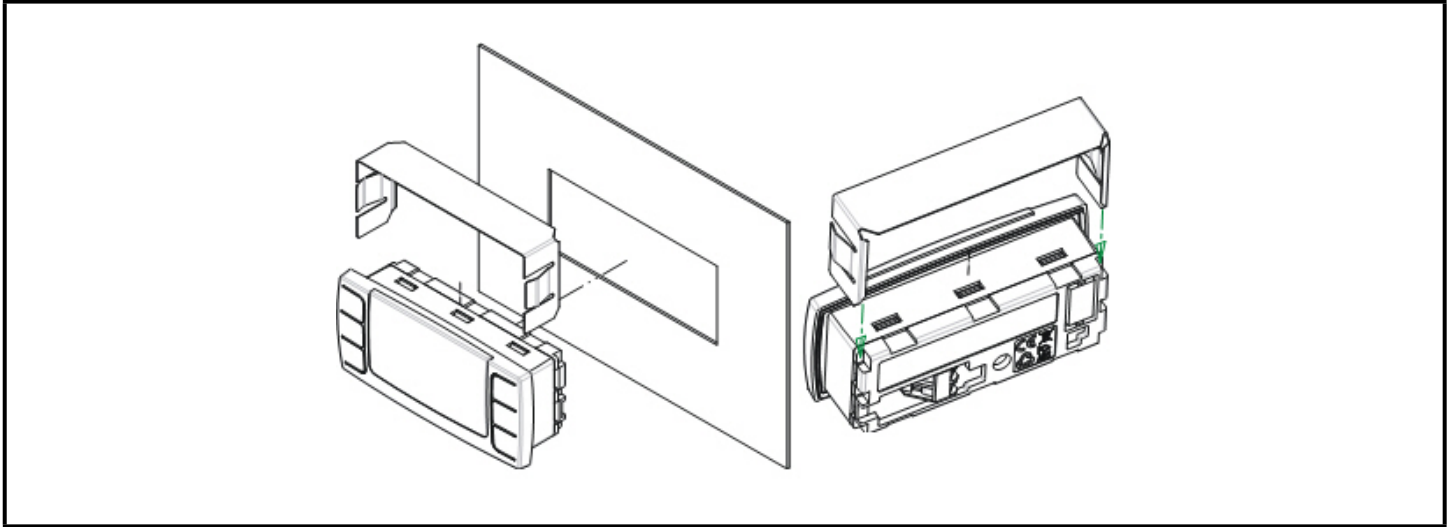

Figure 10-1 - Installation and Mounting of CX660 Keyboard

The temperature range allowed for correct operation is 0 to 60°C. Avoid places subject to strong vibrations, corrosive gases, excessive dirt, or humidity. The same recommendations apply to probes. Allow air to circulate through the cooling holes.

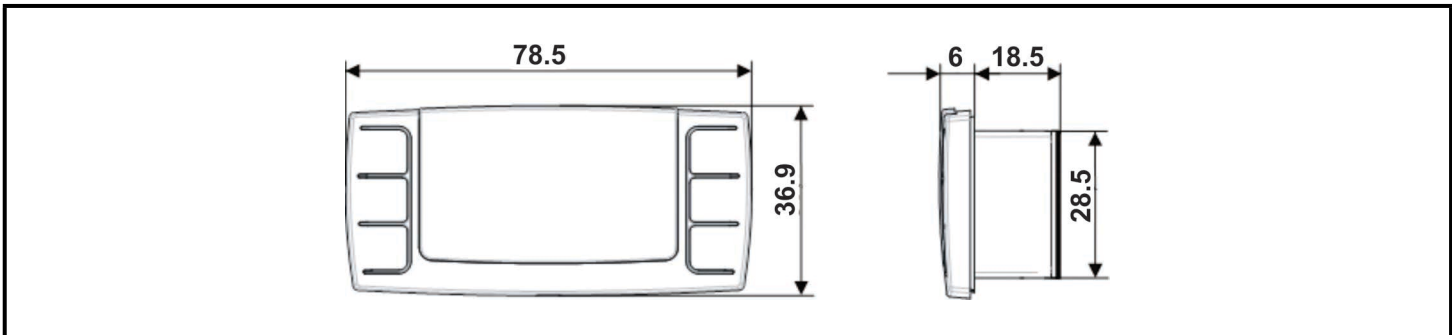

Figure 10-2 - CX660 Keyboard Dimensions

11 Electrical Connections

The XM670/XM679 controllers come with a screw terminal block to connect cables with a cross section up to 1.6 mm² for all the low voltage connections: the RS485, the LAN, the probes, the digital inputs, and the keyboard. Other inputs, power supply, and relay connections are provided with a Faston connection (5.0 mm). Heat-resistant cables have to be used. Before connecting cables, verify that the power supply complies with the controller's requirements. Separate the probe cables from the power supply cables, from the outputs and the power connections. Do not exceed the maximum current allowed on each relay; in case of heavier loads, use a suitable external relay.

NOTE

Maximum current allowed for all the load is 16A.

11.1 Probe Connections

The probes should be mounted with the bulb upwards to prevent damages due to casual liquid infiltration. It is recommended that the thermostat probe be placed away from air streams to measure the average room temperature correctly. Place the defrost termination probe among the evaporator fans in the coldest place, (where most ice is formed) and far from heaters or from the warmest place during defrost to prevent premature defrost termination.

12 RS485 Serial Line

Each XM670/XM679 controller has a direct RS485 connection that enables the controller to be linked to a network line that is MODBUS-RTU compatible with all monitoring systems.

13 How to Use the Hot Key

XM controllers can download or upload the parameter list from its own non-volatile internal memory to the Hot Key and vice-versa through a 5-pin connector. The Hot Key will not change the **Adr**.

13.1 Download (From the Hotkey to the Device)

1. Turn OFF the controller by pressing the on/off button  for five (5) seconds. **OFF** will display. Insert the Hot Key into the 5-pin connector labeled **HOT-KEY**, and then turn the controller back ON by pressing the on/off button again for five (5) seconds. The normal temperature value will display to indicate the controller is ON.
2. The parameter list of the Hot Key is downloaded into the controller memory automatically and **doL** will display. After 10 seconds, the controller will start working with the new parameters.
3. **End** will display at the end of the data transfer phase if the controller is programmed correctly. **Err** will display if there is an error or failure in programming.
 - **End** = correct programming. This means the controller will start regularly with the new programming.
 - **Err** = failed programming. In this case, turn the controller OFF and then ON if you want to restart the download again or remove the Hot Key to abort the operation.
4. Remove the Hot Key.

NOTE: The procedure may fail if the firmware version and the controller models are different.

13.2 Upload (From the Device to the Hotkey)

1. When the XM controller is ON, insert the Hot Key into the 5-pin connector labeled **HOT-KEY**.
2. Press and release the up arrow button.
3. The upload will begin, and **UPL** will blink on the display. **End** will display at the end of the data transfer phase if a successful upload has occurred. **Err** will display if there is an error or failure in programming.
 - **End** = correct programming.
 - **Err** = failed programming. In this case, press the **SET** key if you want to restart the programming again or remove the unprogrammed Hot Key.
4. Remove the Hot Key.

NOTE: The upload procedure will overwrite everything previously uploaded from the last Hot Key upload.

14 Alarm Signals

Table 14-1 - Alarm Signals

Message	Cause	Outputs
KEYBOARD		
nod	No display: the keyboard is trying to work with another board that is not working or not present.	Press the UP arrow for three (3) seconds. Enter the SEC menu, and select LOC entry.
PON	Keyboard enabled	Outputs unchanged
POF	Keyboard locked	Outputs unchanged
rst	Alarm reset	Alarm relay reset
nOP, nP, nA	Probe not present	Compressor output according to parameter Con and COF
noL	The keyboard is not able to communicate with the XM679K.	Verify the connection. Call the service.
ALARM FROM PROBE INPUT		
P1	First probe failure	Compressor output according to parameters Con and COF
P2	Second probe failure	Defrost end is timed
P3	Third probe failure	Outputs unchanged
P4	Fourth probe failure	Outputs unchanged
P5	Fifth probe failure	Outputs unchanged
P6	Sixth probe failure	Outputs unchanged
PPF	PPF is displayed by slaves of pressure that do not receive the value of pressure.	The percentage of the valve opening is fixed at PEO value.
CPF	CPF is displayed when the remote probe 4 is not working,	The percentage of the valve opening is fixed at PEO value.
TEMPERATURE ALARM		
HA	Maximum temperature alarm	Outputs unchanged
LA	Minimum temperature alarm	Outputs unchanged
HAd	Defrost high temperature	Outputs unchanged
LAd	Defrost low temperature	Outputs unchanged
FAd	Defrost low temperature	Outputs unchanged
HAF	Fan high temperature	Outputs unchanged
LAF	Fan high temperature	Outputs unchanged
StP	Stop due to regulation pauses (Sti and Std parameters)	Compressor and valve OFF
DIGITAL INPUT ALARM		
PAL	Lock due to pressure switch	All outputs OFF
dA	Door open	Compressor and fans restarts according to rrd and odc
EA	External alarm	Outputs unchanged
CA	Serious external alarm (i1F=bAL)	All outputs OFF

Table 14-1 - Alarm Signals (Continued) (Continued)

ELECTRONIC VALVE ALARM		
LOP	Minimum operating pressure reached	According to dML
MOP	Maximum operating pressure reached	According to dML
LSH	Minimum superheat alarm	Valve closed
MSH	Maximum superheat alarm	Outputs unchanged
HSH	Minimum superheat alarm	Outputs changed.
CLOCK ALARM		
rtC	Clock settings lost.	Defrost will be performed with IdF until the settings of RTC has been restored.
rtF	Clock damaged.	Defrost will be performed with IdF.
OTHERS		
EE	EEPROM failure	All outputs OFF
Err	Error with upload/download parameters.	Repeat the operation.
End	Parameters have been correctly transferred.	Outputs changed.

14.1 EE Alarm

The controllers are provided with an internal check for data integrity. Alarm **EE** flashes when a failure in the memory data occurs. In such cases, the alarm output is enabled.

14.2 Alarm Recovery

Probe alarms, **P1** (probe1 faulty), **P2**, **P3**, **P4**, **P5**, and **P6** automatically stop 10 seconds after the probe restarts normal operation. Check connections before replacing the probe. Temperature alarms, **HA**, **LA**, **HAd**, **LAd**, **HAF**, and **LAF** automatically stop as soon as the thermostat temperature returns to normal values or when the defrost starts. External alarms **EAL** and **bAL** stop as soon as the external digital input is disabled.

15 Technical Data

Table 15-1- XM670/XM679 Specifications

CX660 KEYBOARD	
Housing	Self-extinguishing ABS
Dimensions	Case: Front: 35 mm x 77 mm Depth: 18 mm
	Panel Mount: 29 mm x 71 mm panel cut-out
Protection	IP20
	Frontal: IP65
Power Supply	From XM600 power module
Display	3 digits, red LED, 14.2 mm H
Optional Output	Buzzer
POWER MODULES	
Case	8 DIN
Connections	Screw terminal block $\leq 1.6 \text{ mm}^2$ heat-resistant wiring and 5.0 mm Faston
Power Supply	Depending on the model: 12VAC - 24VAC - 110VAC $\pm 10\%$ - 230VAC $\pm 10\%$ or 90 to 230VAC with switching power supply
Power Absorption	9VA max
Inputs	Up to 6 NTC/PTC/Pt1000 probes
Digital Inputs	Three (3) voltage-free
Relay Outputs (Total current on loads MAX 16A) See Section 16, UL Ratings.	
Valve Output	a.c. output up to 30W (Only XM679)
Optional Output (AnOUT) Depending on the model	PWM/ Open Collector outputs: PWM or 12VDC max 40mA Analog Output: 4 to 20mA or 0 to 10V
Serial Output	RS485 with MODBUS-RTU and LAN
Data Storing	On the volatile memory (EEPROM)
Kind of Action	1B
Pollution Grade	Normal
Software Class	A
Operating Temperature	32 to 140°F (0 to 60°C)
Storage Temperature	-13 to 140°F (-25°C to 60°C)
Relative Humidity	20 to 85% (no condensing)

Table 15-1- XM670/XM679 Specifications

Measuring and Regulation Range	NTC probe: -58 to 230°F (-40 to 110°C)
	PTC probe: -67 to 302°F (-50 to 150°C)
	Pt1000 probe: -148 to 212°F (-100 to 100°C)
Resolution	0.1°C or 1°C or 1°F (selectable)
Accuracy (ambient temperature 25°C)	±0.5 °C ±1 digit

16 UL Ratings

Table 16-1- XM670/XM679 UL Ratings

	Ratings	Terminal
Relay Outputs UL Ratings	Evaporator Fan: 120/240 V, 50/60 Hz, 1/4 HP, 30k cycles 125 V, 50/60 Hz, 1/3 HP, 6k cycles 250 V, 50/60 Hz, 1/2 HP, 30k cycles	Terminals 9 and 10
	Compressor: 120 V/240 V, D300 Pilot Duty, 30k cycles	Terminals 11 and 12
	Auxiliary (not populated in XM66 series): 120/240 V, 50/60 Hz, 5 A, General Purpose, 6k cycles 120/240 V, 50/60 Hz, 3 A, Resistive, 100k cycles	Terminals 18 and 17
	Light: 120 V, 50/60 Hz, 5 A, General Purpose, 6k cycles, 120 VAC, 1000 W Tungsten, 6k cycles 240 VAC, 1400 W Tungsten, 6k cycles	Terminals 16 and 15
	Defrost: 120/240 V, 50/60 Hz, 10A, Resistive, 30k cycles 120/240 V, 50/60 Hz, C300, Pilot Duty, 30k cycles	Terminals 14 and 13
	Alarm (not populated on XM66 series): 120/240 V, 50/60 Hz, 5 A, General Purpose, 6k cycles 120/240 V, 50/60 Hz, 3 A, Resistive, 100k cycles	Terminals 1, 2 and 3
	Pulse Valve (not populated on XM66 series): 230 V, 30 Watt	Terminals 4, 5 and 6

Temperature - Maximum ambient operating temperature 60°C.

Pollution Degree - 2 (Normally only non-conductive pollution. However, a temporary conductivity caused by condensation may be expected.)

17 Connections

17.1 E2 to XM Device Communication Recommendations

Baud Rate: 19.2K Baud (9600 baud is not recommended for E2 to XM device communications).

Cable Length: Belden 8761 or equivalent (1200ft or less).

I/O Net Biasing: Up to 25 XM6xx devices can be connected to each E2 COM2A, COM2B, COM4A, COM4B and COM6 port. Contact Technical Service if you have more than 25 devices per COM segment.

17.1.1 Wiring Guidelines

Table 17-1 - Wiring Guidelines

DEVICE TYPE	COPELAND
ANALOG TEMP SENSOR DIGITAL INPUT	BELDEN #8761 #22-2 SHIELDED Copeland P/N 035-0002
RS-485 NETWORK	BELDEN #8761 #22-2 SHIELDED Copeland P/N 035-0002 BELDEN #8641 #24-2 SHIELDED Copeland P/N 135-8641
PRESSURE TRANSDUCER	**BELDEN #8771 #22-3 SHIELDED Copeland P/N 135-8771 **#8771 for alternate 600v rated wire use BELDEN #8618 16 AWG
POWER, LOADS, AND VALVE	Allows a maximum wire size of 14 AWG (2 mm ²).

17.2 XM670 - Wiring Diagram

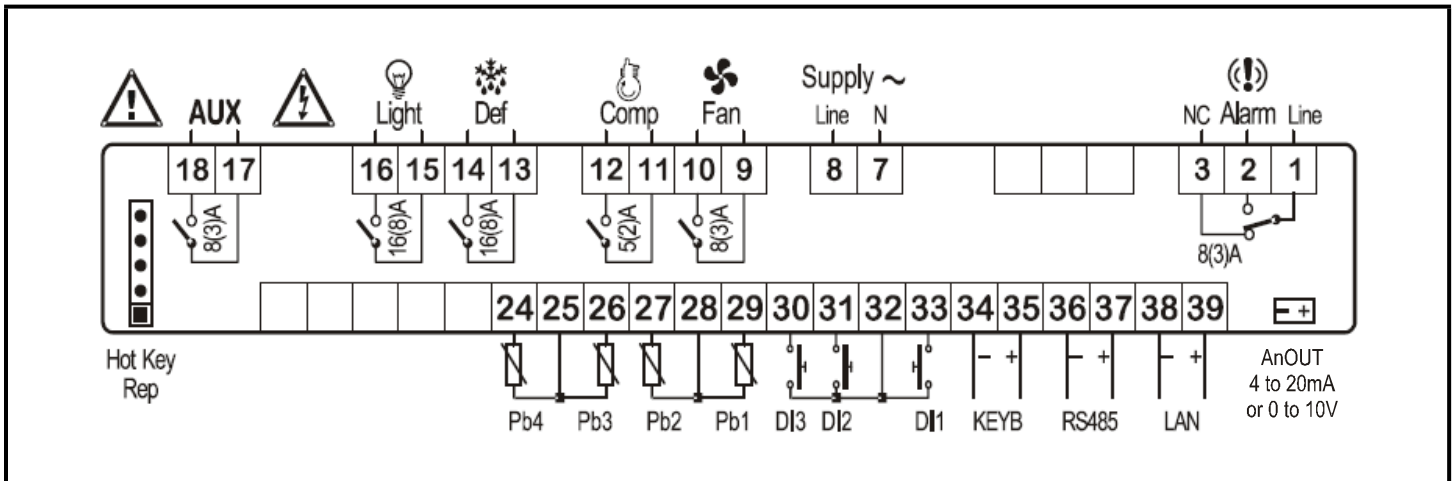

Figure 17-1 - XM670 - ALL Power Supply

17.3 XM679 - 230VAC Valves/Wiring Diagram

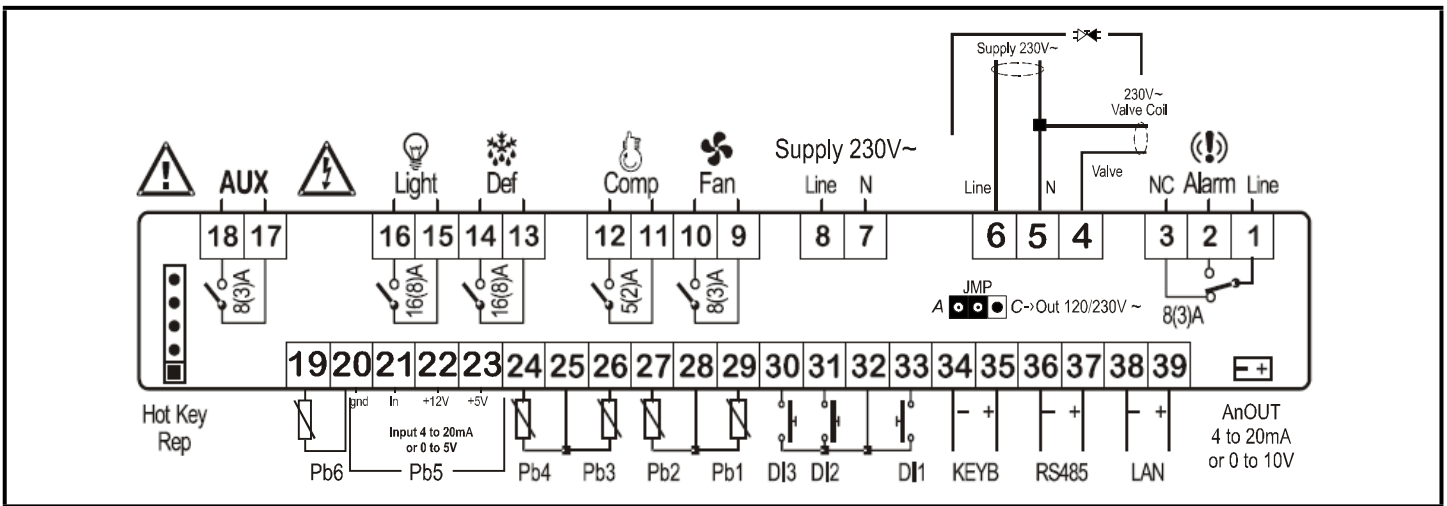

Figure 17-2 - XM679 - 230VAC Valves

Models at 115V

Supply: Terminals 7-8

Valve at 115V: Terminals 4-5

17.4 XM679 - 24VAC Valves/Wiring Diagram

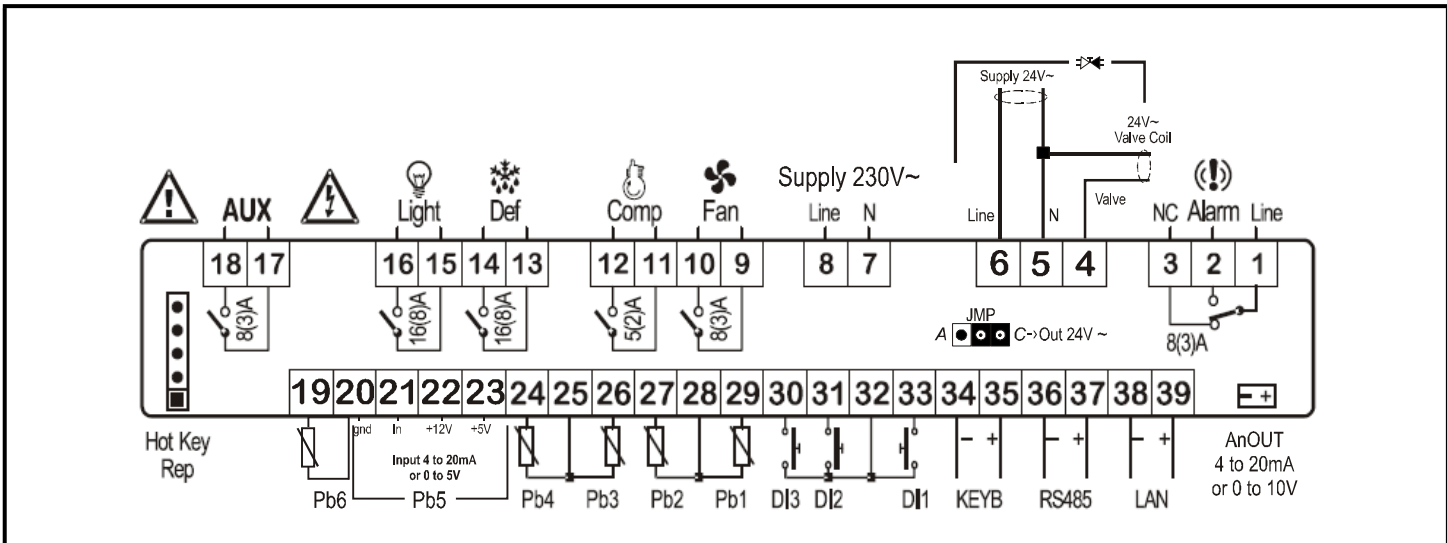

Figure 17-3 - XM679 - 24VAC Valves

NOTE

The jumper labeled as JMP is located inside the case of the controller. The JMP jumper should be closed only when driving the 24VAC valve.

18 E2 MODBUS Network Wiring

- Connect the MODBUS Network to the RS485 Connector on the E2 PIB board (Belden 8641 recommended).
- Note to wire the RS485 +/- polarity at the E2 in the reverse of the XM670 - XM679 devices.
- Position the three termination jumpers to the UP (terminated) position to provide RS485 termination at the E2.
- Do not connect the shield of the MODBUS network to the E2 PIB center terminal. Instead, use a 100 ohm 1/2 watt resistor to connect the MODBUS cable shield to earth ground.
- At each XM670 - XM679 device, wire the MODBUS cable to the RS485 +/- terminals and connect the MODBUS shield to the pin **38** terminal.
- Terminate the end of the MODBUS network at the last XM670 - XM679 device on the daisy chain with the MODBUS termination block (P/N 535-2711), or by connecting a 150 ohm resistor between the MODBUS +/- terminals.

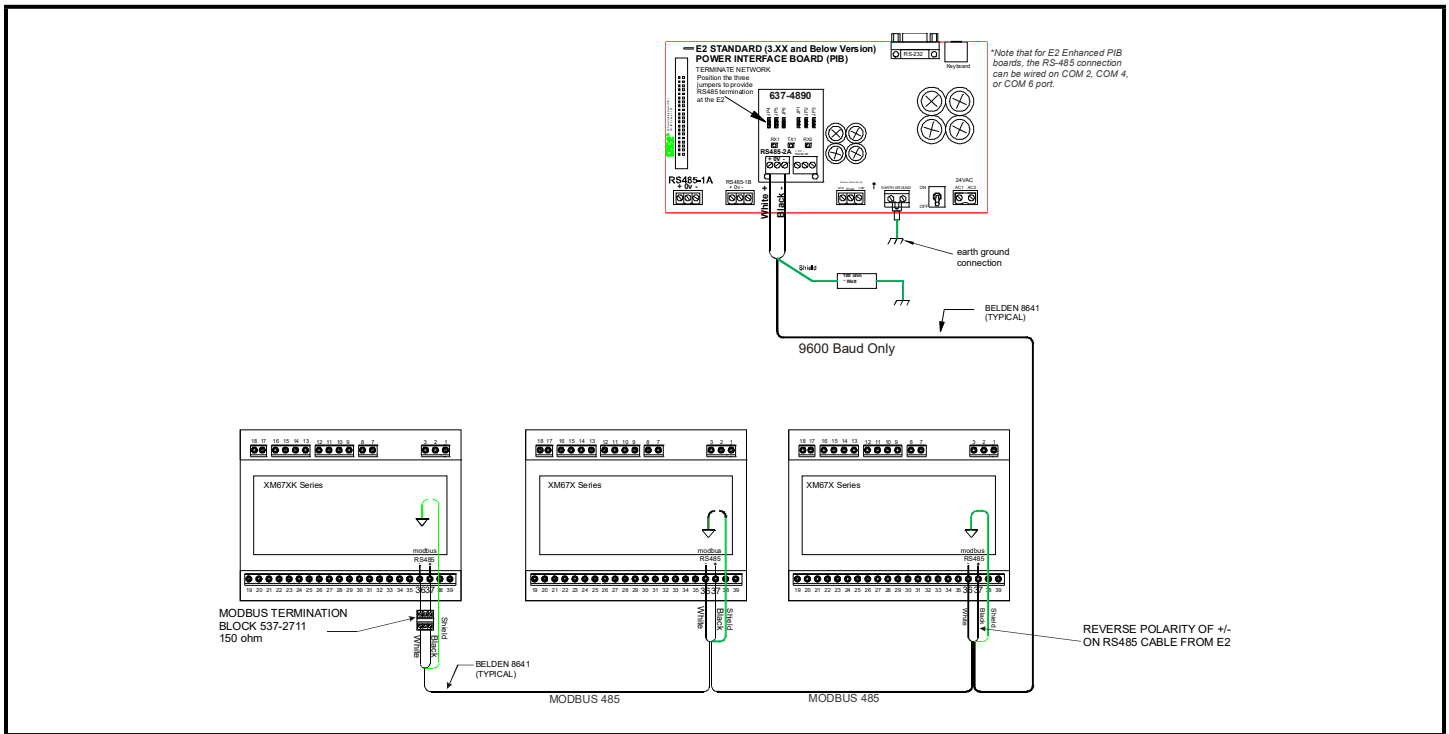

Figure 18-1 - XM670 - XM679 to E2 MODBUS Network Wiring



For the XR, XM, and XEV series of controllers, the shield wire must not come into contact with any other wire or ground source. If contact with other wires or devices does occur, the 485 MODBUS network will malfunction or connected devices will be damaged. This applies to all installations where the shield is tied to ground through a 100 ohm ½ Watt resistor.

Refer to *Appendix A - Alternate MODBUS COM Wiring Method for E2, XR, XM, and XEV Devices.* (Technical Bulletin P/N 026-4148.)

19 Wiring Layout for Sharing a Pressure Transducer on a LAN

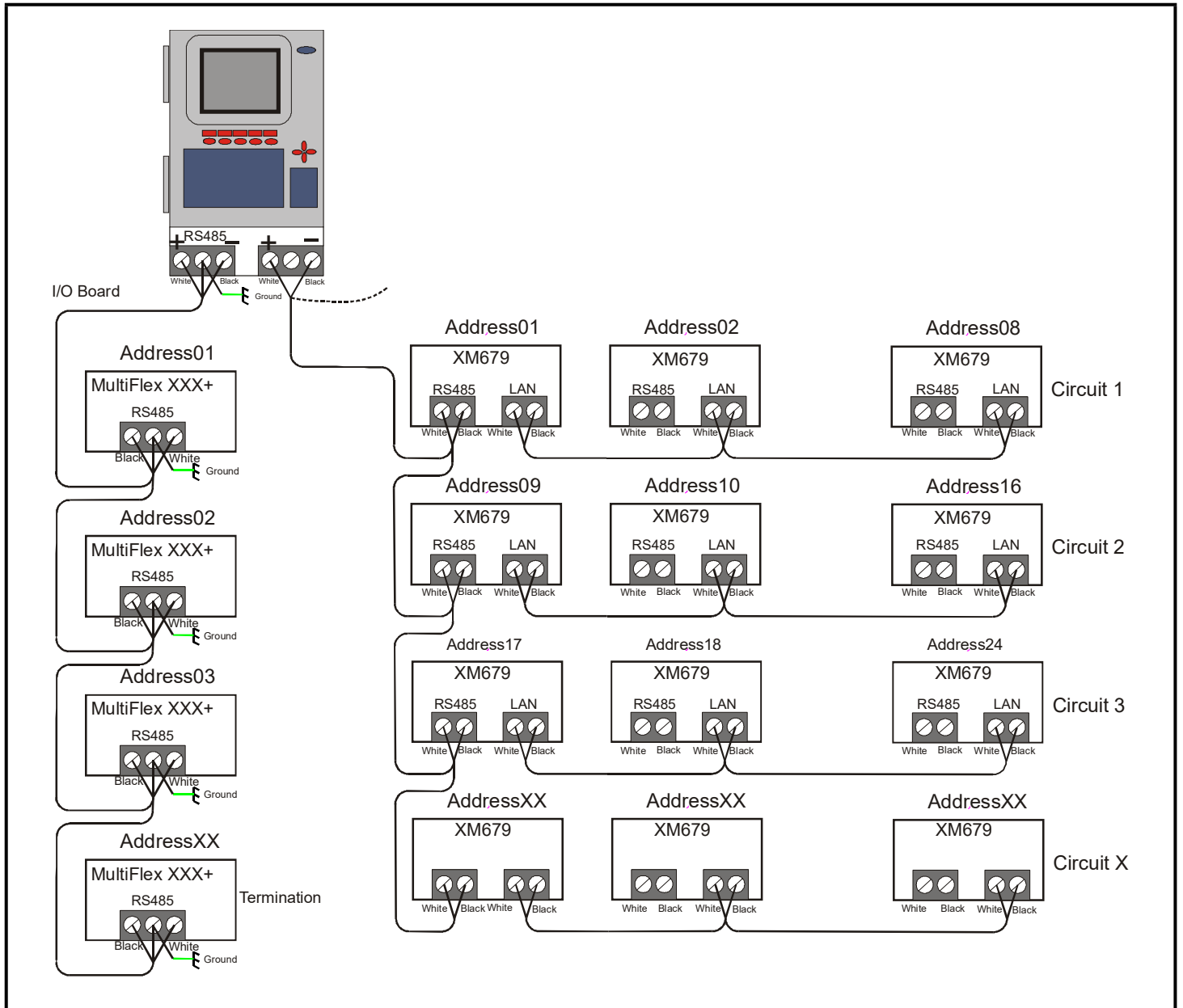
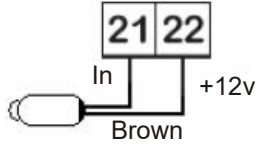
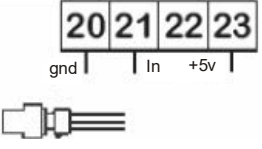

Figure 19-1 - Wiring Guidelines for Sharing a Pressure Transducer Across Multiple Units on the Same Circuit - XM679 Only

20 Pressure Transducer Setup (XM679 Only)

	<p>4 to 20 mA for PP07, PP11, or similar models</p>
	<p>Generic metric ratio 0 to 5V</p>

Virtual Pressure: In this example of programming, the master device is the regulator with the pressure probe connected.

A working LAN connection is required (green LED lit on all XM679K boards of the same LAN). Connect and configure a pressure transducer only on one XM679K of the network. Afterwards, the value of the pressure read by the unique transducer connected will be available to each device connected to the same LAN.

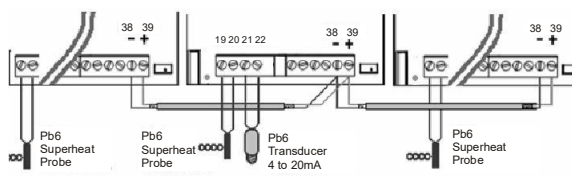
Slave	Master	Slave
<p>tPP = LAn LPP = n P5C = nP</p>	<p>tPP = PP LPP = Y P5C = 420 (transd.)</p>	<p>Tpp = LAn LPP = n P5C = nP</p>
		
<p>Press the arrow keys to access menu readings for pressure.</p>		
<p>Once set up, check these readings:</p>		
<p>Slave device pressure: rPP: Shows the value of pressure received by remote pressure probe connected to other XM600 device.</p>	<p>Master device pressure: dPP = Shows the value of pressure measured by pressure transducer. dP5 = Shows the temperature value measured by probe 5.</p>	<p>Slave device pressure: rPP: Shows the value of pressure received by remote pressure probe connected to other XM600 device.</p>

Check for error messages. Error message examples:

- **dPP = Err:** in the Master device, the value of pressure read from the transducer is outside the acceptable range regarding parameters **PA4- PA20**; is connected incorrectly or it is not configured to parameter **P5C**.
- **PPF** = reading on the slave device - LAN communication is not functional.
- **tPP = LAn:** in the master controller, LAN address sequences are not correct. **LPP = Y** means the address sequences are not correct.

Final Control From Superheat (**SH**) Reading Control Values:

- **dPP** = Shows the value of pressure measured by pressure transducer.
- **dP6** = Shows the temperature measured by probe 6. Corresponds to the outlet temperature of gas of the evaporator.
- **SH** = Shows the actual superheat value. It must have a consistent value for difference between the values **dP6** and **dP5**. If displaying **nA**, **err** or **nd**, the value is not calculable at the moment of the reading.

20.1 Keyboard Display CX660

1. Terminals -34 and +35
2. Use twisted shielded cable AWG 18 or less in case of long distance.
3. Keep at a maximum distance of 30m.

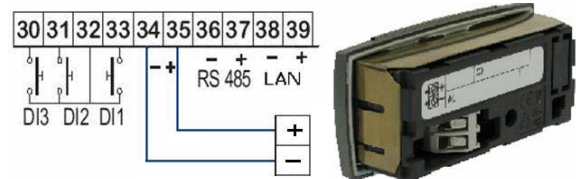

The XM679 board can also operate without a keyboard.

20.2 Synchronized Defrost

The synchronized defrost (also called master-slave functioning) allows the user to manage multiple defrost from different boards connected through the LAN connection. In this way, the boards can perform simultaneous defrosts with the possibility to end them in a synchronized way.

Follow the next steps to create a LAN connection, which is a necessary condition to perform synchronized defrost.

1. Connect a shielded cable between terminals -38 and +39 for a maximum of 8 sections.
2. The Adr parameter identifies each electronic board. Address duplication is not permitted. In this case, the synchronized defrost and the communication with the monitoring system is not guaranteed. (The Adr is also the MODBUS address). For example, a correct configuration would be:

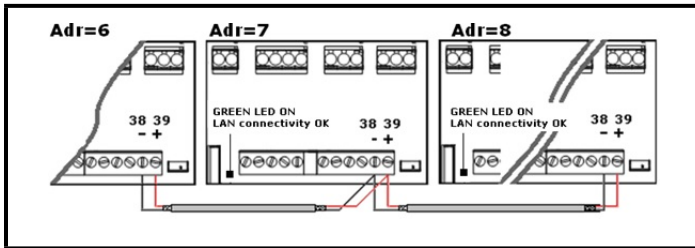

Figure 20-1 - Synchronized Defrost

If the LAN is well connected, the green LED will be ON. If the green LED blinks, then the connection is wrongly configured. The maximum distance allowed is 30m.

20.3 Sensors for Superheat Control

	<p>Temperature probe: Pb6 terminals [19]-[20] without any polarity.</p> <p>Select the kind of sensor with P6C parameter.</p> <p>Pressure transducer: Pb5 terminals: [21] = input of the signal [22] = Power Supply for 4 to 20 mA transducer [20] = GND [23] = +5Vdc power supply for ratiometric pressure transducer</p>
--	---

Select the configuration of the transducer with parameter P5C.

20.4 Analog Output

	<ul style="list-style-type: none"> • Selectable between 4 to 20mA and 0 to 10Vdc. • Use CABJC15 to perform the connections.
--	---

The analog output is located near the terminal [39] on a 2-pin connector. The output can be used to control anti-sweat heaters through a chopped phase controller XRPW500 (500 watt) or family XVD or XVK.

20.5 RS485 Net Monitoring Temperatures

	<ol style="list-style-type: none"> 1. Terminals -36 and +37 2. Use Belden cable #8761 or #8641. 3. Keep at a maximum distance of approximately 1Km. 4. Don't connect the shield to the earth or to GND terminals of the device. Avoid accidental contact by using insulating tape.
--	--

20.5.1 RS485 Connection

Sharing a single pressure transducer across multiple controllers on a LAN:

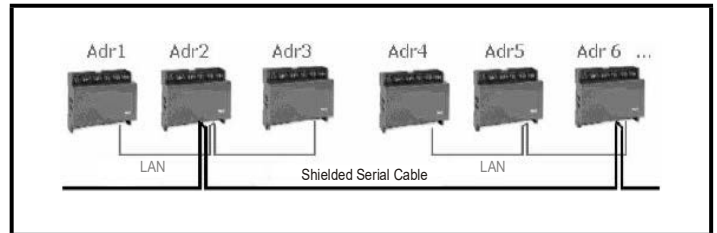

Figure 20-2 - Sharing a Pressure Transducer Between Devices on LAN





CAUTION

Do not connect the RS485 cable to all the instruments that are already connected on the LAN - only connect the RS485 to the master device of the LAN.

The parameter (**Adr**) also defines the number of configurations on the RS485 network (besides the **LAN**); its value must be only from 1 to the total number of devices present on the RS485 and the LAN networks.

CAUTION

The same value of the Adr parameter in different controllers creates malfunctioning in the monitoring system or problems on the synchronized defrosts.

SET + 	Press for three (3) seconds, the rtC or other will be shown. The measurement unit blinks.
	Press more than once the DOWN arrow to find the Adr parameter, then press SET .
 + 	Set the value of Adr parameter, then press SET to confirm the parameter.
SET + 	Press the two keys together to exit from the menu or wait for about 10 seconds.

20.6 How to Enable a Pressure Probe to Share Across the LAN

1. Enter the **Pr1** level. Follow the steps in **Section 3.7, How to Enter the Parameters List PR1**.
2. Select **Pr2** parameter and press the **SET** key.
3. The **PAS** flashing message will display, followed shortly by “**0 --**” with a flashing zero.
4. Use the **UP** or **DOWN** button to input the security code in the flashing digit. Confirm the security code by pressing **SET**. The security code is **321**.
5. If the security code is correct, the access to Pr2 is enabled by pressing **SET** on the last digit.
6. Navigate to the **LPP** of the Master device (the device where the pressure probe is connected) and select **(Y)**. Set the **LPP** to **(N)** for all other slave devices.
7. Navigate to **tPP** of the Master device and set it to **PP** (Pressure Probe). The slave devices **tPP** parameter will be set to **LAN**.
8. Navigate to **P5C** parameter (Pressure Probe will always be assigned to **P5C**) of the Master device and set it to Pressure Probe type. The slave devices **P5C** parameter will be set to **nP** (No Probe).

NOTE

If pressure is not being shared across the LAN, each XM679 will need its own Pressure Transducer. Please reference **Figure 18-1** and **Figure 19-1** wiring diagrams.

21 Wiring Connection to Site Supervisor

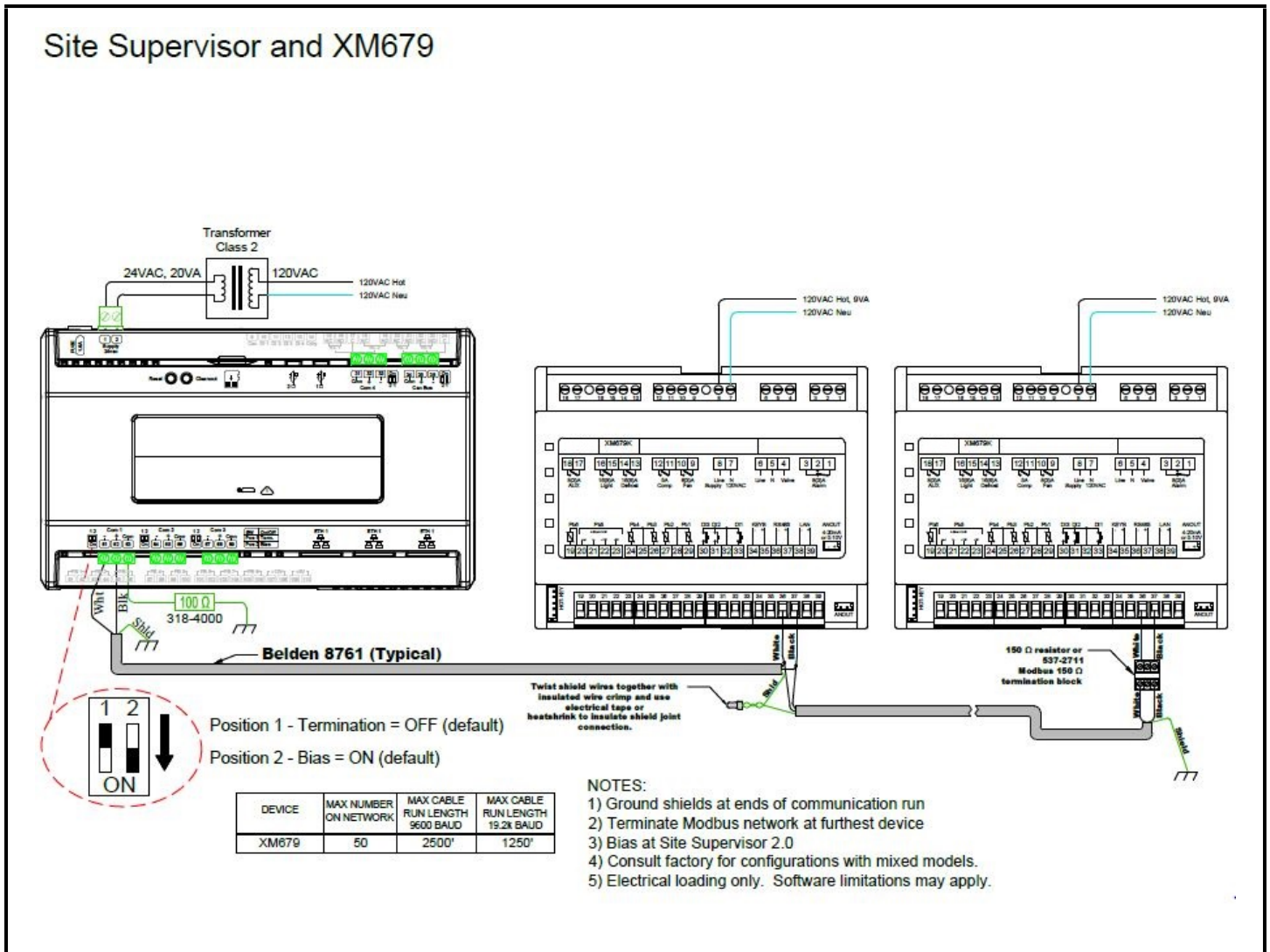

Figure 21-1 - Site Supervisor Wiring

22 MODBUS Networking to E2s

Connecting a XM670 - XM679 controller to an E2 requires the E2 to be version 2.84 or above. Contact Copeland for upgrade information if the controller is a version before 2.84.

22.1 COM Port Associations - E2 Versions 3.xx and Below

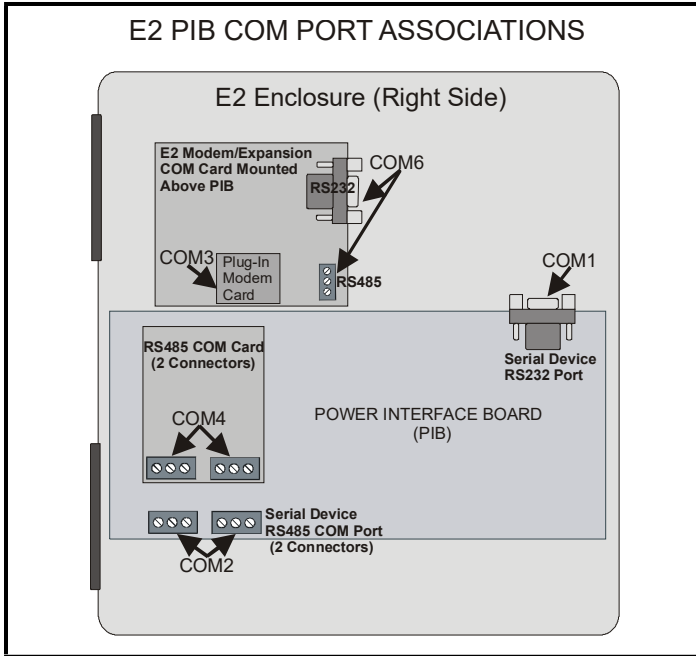

Figure 22-1 - Location of E2 Com Ports - E2 PIB Board (E2 versions 3.xx and Below)

An E2 has up to three COM ports that can be assigned for MODBUS communication: COM2, an RS485 port on the E2 power interface board, and COM4 and COM6, which are optional ports requiring expansion cards. COM4 is recommended for MODBUS connection of XM670 - XM679 units.

COM ports can only be used for one function; in other words, if COM2 is set up as the I/O network, you cannot connect MODBUS devices to COM2. Ensure your E2 is equipped with an RS485 COM Card (P/N 637-4890) and configured in E2 General Services (Menu **& 7 3 1**, **Serial** tab) to enable COM4 or an E2 Expansion COM Card (P/N 637-4871) to enable COM6.

Connect the MODBUS network cable to the three-terminal connector on the COM port you wish to assign as MODBUS. Reverse polarity of +/- on RS485 cable from E2 to the device.

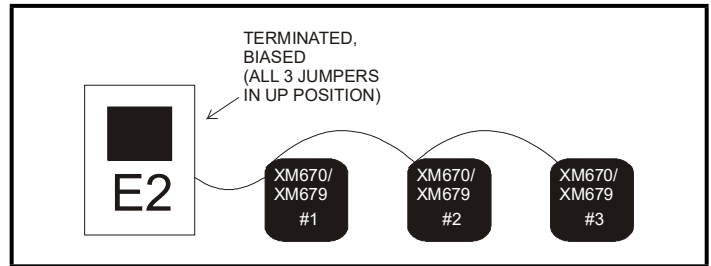

Figure 22-2 - MODBUS Networking

22.2 COM Port Associations - E2 Versions 4.0 and Above

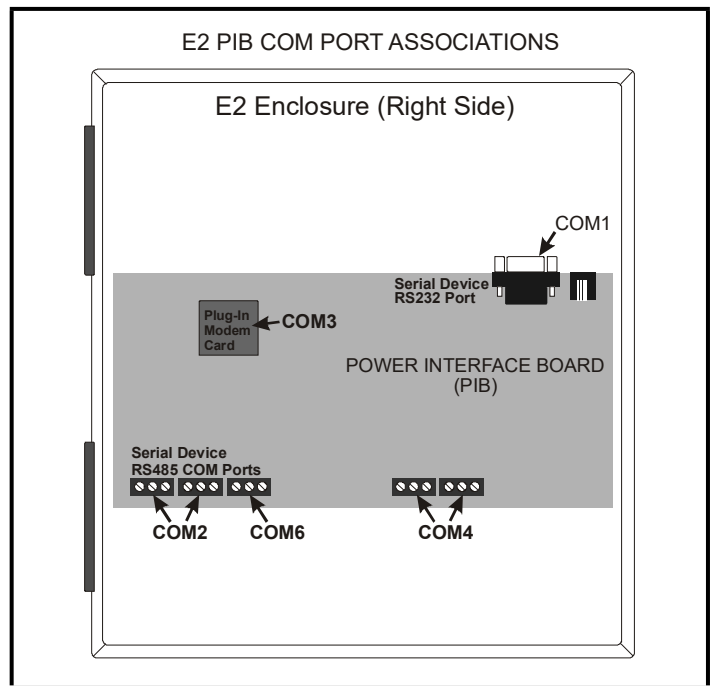

Figure 22-3 - Location of E2 Com Ports - E2 PIB Board (E2 versions 4.0 and Above)

An E2 has three COM ports that can be assigned for MODBUS communication (COM2). COM ports can only be used for one function; in other words, if COM2 is set up as the I/O network, you cannot connect MODBUS devices to COM2. Ensure your E2 is configured in E2 General Services (Menu **& 7 3 1**, **Serial** tab) to enable COM4 or COM6.

Connect the MODBUS network cable to the three-terminal connector on the COM port you wish to assign as MODBUS. Reverse polarity of +/- on RS485 cable from E2 to the device.

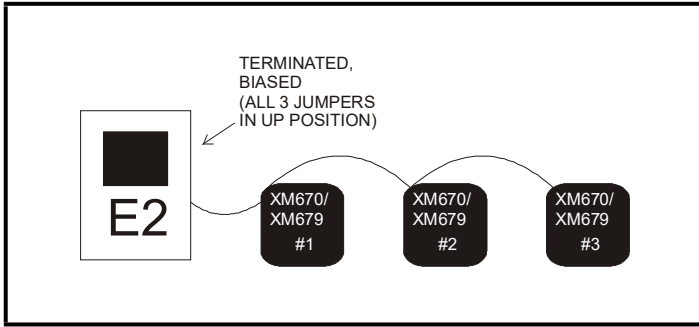

Figure 22-4 - MODBUS Networking

22.3 E2 Setup of Devices

22.3.1 Set Up Network Ports

Before setting up a device, the port on the E2 that has the MODBUS cable connected must be set up as a MODBUS port.

1. Log in to the E2 with Level 4 access.
2. Press followed by - **General Controller Info**.
3. Press + to open the **Serial** tab of the **General Controller Info** setup screens:

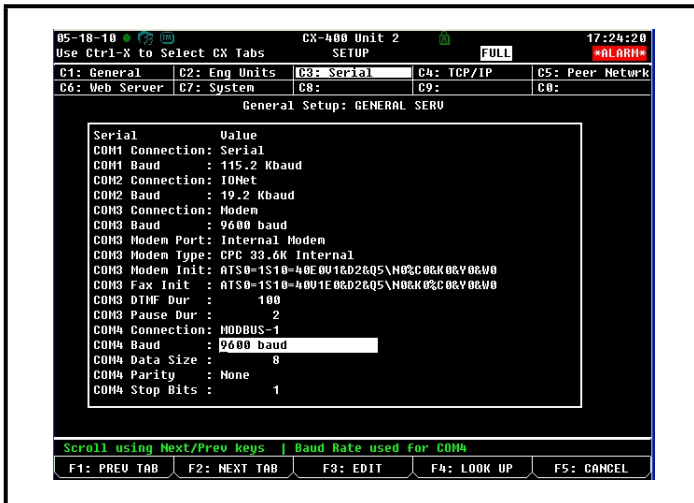

Figure 22-5 - Serial Communications Manager Screen

4. This screen will have a "Connection" field for all COM ports on the E2. Highlight the COM port connection field that will be used for the device, and press - **LOOK UP**. From the list of network types, select **MODBUS**.

5. Four fields will become visible underneath the COM port connection field, which pertain to the way the device communicates:
 - **Baud** - Default setting is **19.2k**. The baud rate setting should be set to match the baud rate of the XM670 - XM679 device (**9600**). (All devices connected to the same COM port should be set to the same baud rate.)
 - **Data Size** - Leave this field at the default value (**8**).
 - **Parity** - Leave this field at the default value (**None**).
 - **Stop Bits** - Leave this field at the default value (**1**).
6. Press to save changes and exit.

22.3.2 Add and Connect the Device

To enable communications between E2 and the XM670 - XM679 units, the devices must be added and addressed in E2.

1. Log in to the E2 with Level 4 access.
2. Press - **Connected I/O Boards and Controllers**.

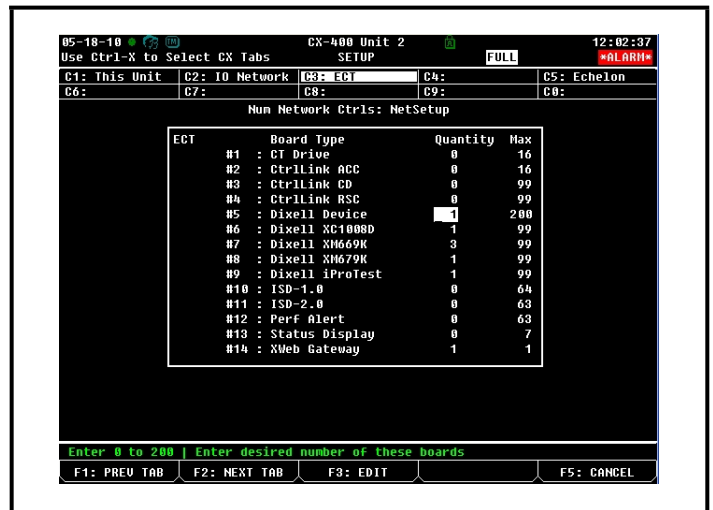

Figure 22-6 - Num Network Ctrls: NetSetup Screen

3. In the *Num Network Ctrls: NetSetup* screen, under the **ECT** tab, enter the number of devices in the **Quantity** field. (**Max** shows the maximum number of devices allowed on the network.)
4. Press to return to the *Network Setup* menu, then select - **Network Summary**.

- Locate the units you added to the network list (press **Page Up** and **Page Down** to scroll through the list). If desired, enter a new name for each device in the **Name** field.

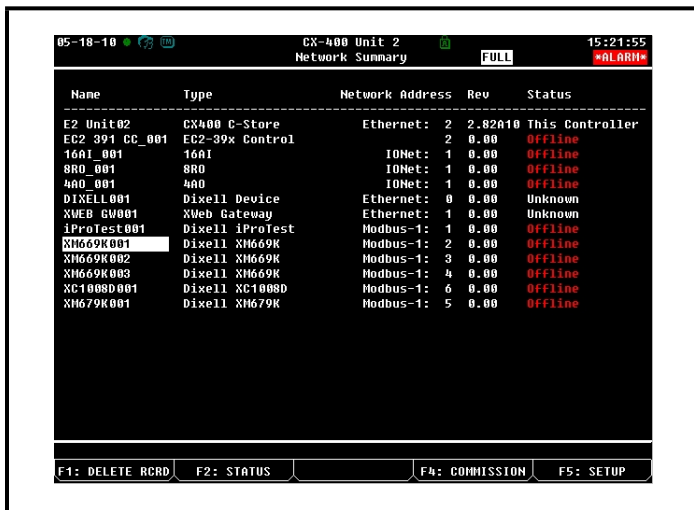

Figure 22-7 - Network Summary Screen

- By default, each device in the network list has a board number of 0. To set the address and begin communication, choose the device and press **F4**. In the list of MODBUS devices, choose the address number corresponding to the XM670 - XM679 address set up through the front display, and press **Enter** to select it. A window will open where you can specify the address of the controller. If a network ID has already been selected, its name will be shown next to the network ID in this list. If the network ID you are trying to assign has already been used, you must set the address on this device to a different number that is not being used.

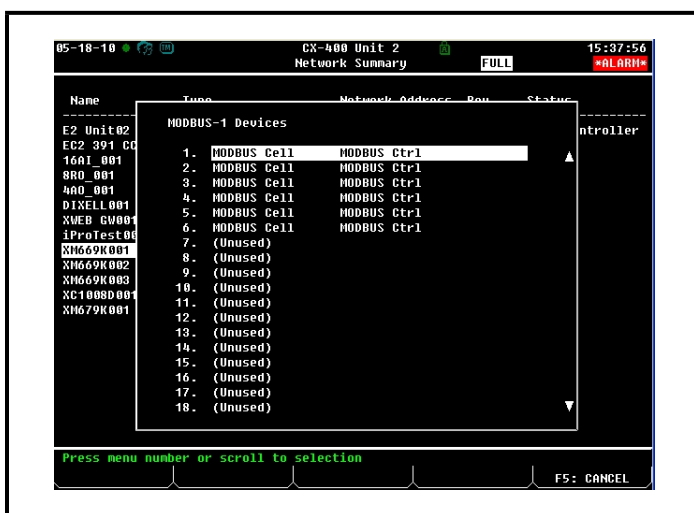

Figure 22-8 - List of MODBUS Devices

- Repeat **Steps 5** and **6** until each device has a name and address.
- When finished, press **ESC** to return to the *Network Setup* menu, then press **1** - **Network Summary (Figure 22-7)**. Locate the devices you set up, and look at each device's status in the **Status** field. You will see one of the following messages:
 - Online** - The device is communicating normally.
 - Offline** - The device is not communicating, has not been commissioned, is not functional, or is not powered up. Verify the device is powered up, wired correctly, and has the proper network address, baud rate, and parity.
 - Unknown** - The device is not communicating or has not been commissioned. Verify the device is powered up, wired correctly, and has the proper network address, baud rate, and parity.
 - No Port** - No port is set up in the E2 Serial Configuration Manager to be a MODBUS port.
 - Wrong FW Rev** - This message is likely caused by the device having a firmware version older than the minimum revision required by E2 for communication. Replace the device with a new one or a device that has the latest version of firmware on it.

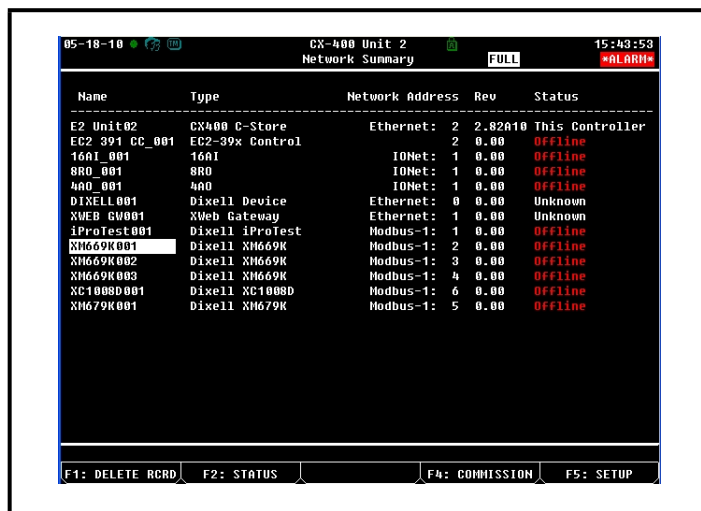

Figure 22-9 - Network Summary Screen

22.4 Wiring Types

Copeland specifies Belden #8761 shielded twisted pair cables for use as MODBUS wiring (or Belden #82761 and Belden #88761 for plenum installations).

For MODBUS network wiring of XM670 - XM679 controllers to E2, Belden #8641 (*Copeland P/N 135-8641*) is the recommended wire type to use.

If the recommended cable is not available in your area, be sure the wiring meets or exceeds the following specs:

Shielded?	Yes
Conductor Type	Twisted Pair
Gauge	18 - 24 AWG
Capacitance between signal wires	31 pF/ft or less (9.45 m) or less
Capacitance between signal and shield	59 pF/ft or less (17.98 m) or less
Maximum Length	4000 ft/18 to 22 AWG (1219.2 m) 2500 ft/24 AWG (762 m)
Nominal Impedance	120W±50W

22.5 MODBUS Termination Blocks

Because the XM670/XM679 device has no on-board means of termination, use the MODBUS termination block (*P/N 535-2711*) for termination that can be wired to the end of the cable segment using the three-pin connector. Wire the two signal wires to the outside terminals, and connect the shield to pin 38 of the device, keeping the exposed shield wire length as short as possible (3 inches ideal maximum length).

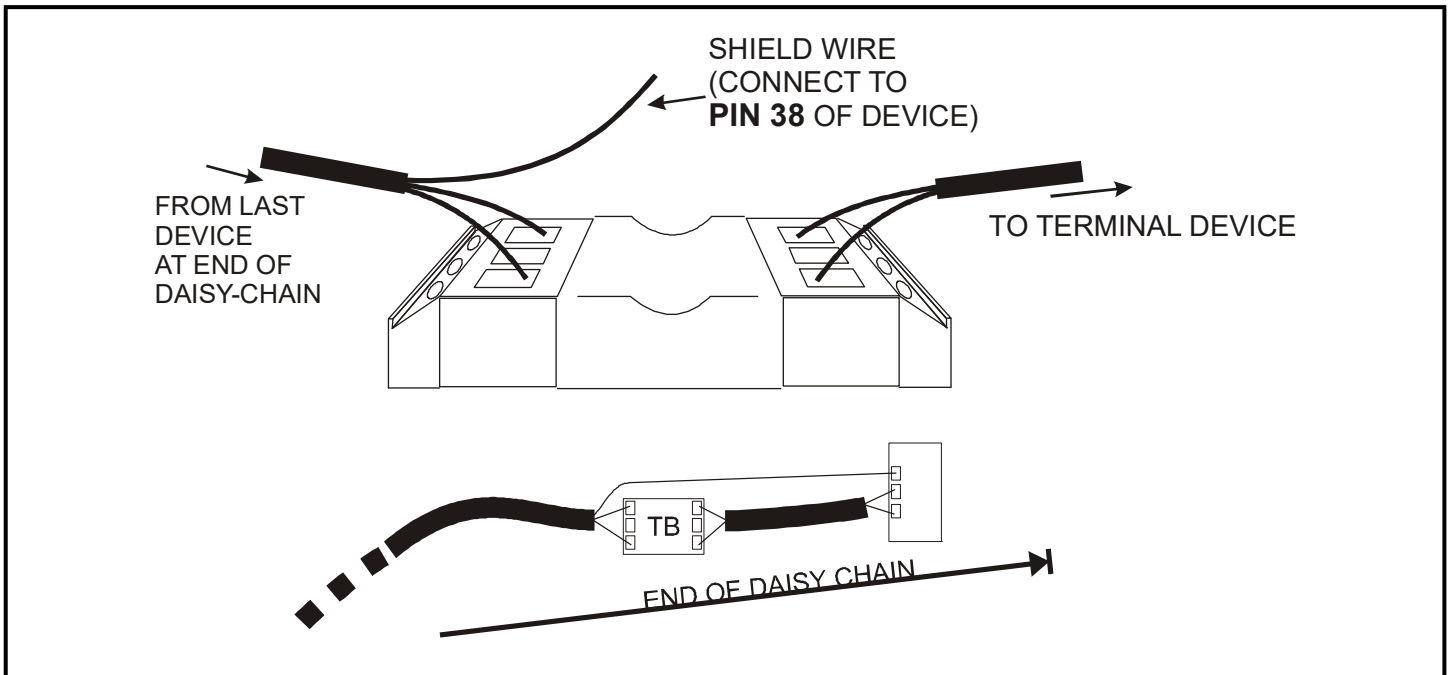

Figure 22-10 - MODBUS Termination Block (P/N 535-2711)

23 Default Setting Values

Table 23-1 - Default Setting Values

Label	Value	Menu	Description	Range
SEt	2.0	---	Setpoint	LS - US
REGULATION				
Hy	2.0	Pr1	Differential	[1°F to 45°F] [0.1°C to 25.5°C]
Int	150	Pr1	Integral time for room temperature regulation	0 to 255 s
CrE	n	Pr1	Continuous regulation activation	n(0) - Y(1)
LS	-30	Pr2	Minimum setpoint	[-67°F to SET] [-55.0°C to SET]
US	20	Pr2	Maximum setpoint	[SET to 302°F] [SET to 150.0°C]
odS	0	Pr1	Outputs activation delay at start up	0 to 255 (min.)
AC	0	Pr1	Anti-short cycle delay	0 to 60 (min.)
CcT	0.0	Pr2	Continuous cycle duration	0 to 24.0(144) (hour.10min)
CCS	2.0	Pr2	Continuous cycle setpoint	[-67°F to 302°F] [-55.0°C to 150.0°C]
Con	15	Pr2	Compressor ON time with faulty probe	0 to 255 (min.)
CoF	30	Pr2	Compressor OFF time with faulty probe	0 to 255 (min.)
CF	°C	Pr2	Measurement unit: Celsius, Fahrenheit	°C(0) - °F(1)
PrU	rE	Pr2	Pressure Mode	rE(0) - Ab(1)
PMU	bAr	Pr2	Pressure measurement unit	bAr(0) - PSI(1) - MPA(2)
PMd	PrE	Pr2	Pressure displaying mode: temperature or pressure	tEM(0) - PrE(1)
rES	dE	Pr2	Resolution (only °C): decimal, integer	dE(0) - in(1)
Lod	P1	Pr2	Local display: default display	nP(0) - P1(1) - P2(2) - P3(3) - P4(4) - P5(5) - P6(6) - tEr(7) - dEF(8)
rEd	P1	Pr2	Remote display: default display	nP(0) - P1(1) - P2(2) - P3(3) - P4(4) - P5(5) - P6(6) - tEr(7) - dEF(8)
dLy	0	Pr1	Display delay	0 to 24.0(144) (Min.10s)
rPA	P1	Pr1	Regulation probe A	nP(0) - P1(1) - P2(2) - P3(3) - P4(4) - P5(5)
rPb	nP	Pr1	Regulation probe B	nP(0) - P1(1) - P2(2) - P3(3) - P4(4) - P5(5)
rPE	100	Pr1	Virtual probe percentage (room temperature)	0 to 100 (100=rPA, 0=rPb)

Table 23-1 - Default Setting Values (Continued)

ELECTRONIC EXPANSION VALVE				
Fty	404	Pr1	Kind of gas	R22(0) - 134(1) - 404(2) - 407(3) - 410(4) - 507(5) - CO2(6)
SSH	8.0	Pr1	Superheat setpoint	[1°F to 45°F] [0.1°C to 25.5°C]
CyP	6	Pr1	Cycle Period	1 to 15 s
Pb	5.0	Pr1	Proportional band for superheat regulator	[1°F to 108 °F] [0.1°C to 60.0 °C]
rS	0.0	Pr1	Band Offset for superheat regulator	[-21°F to 21°F] [-12.0°C to 12.0°C]
inC	120	Pr1	Integration time for superheat regulator	0 to 255 s
PEO	50	Pr1	Probe error opening percentage	0 to 100
PEd	On	Pr1	Probe error delay before stopping regulation	0 to 239 s - On(240)
OPE	85	Pr1	Start opening percentage	0 to 100
SFd	1.3	Pr1	Start function duration	0 to 42.0(252)(min.10sec)
OPd	100	Pr1	Opening percentage after defrost phase	0 to 100
Pdd	1.3	Pr1	Post defrost function duration	0 to 42.0(252)(min.10sec)
MnF	100	Pr1	Maximum opening percentage at normal functioning	0 to 100
dCL	0	Pr1	Delay before stopping valve regulation	0 to 255 s
Fot	nu	Pr1	Forced opening percentage	0 to 100 - "nu"(101)
tPP	PP	Pr2	Type of pressure transducer	PP(0) - LAN(1)
PA4	-0.5	Pr2	Probe value at 4 mA or at 0V	BAR: [PrM = rEL] -1.0 to P20 [PRM = Abs] 0.0 to P20 PSI: [PrM = rEL] -14 to P20 [PRM = Abs] 0 to P20 dKP: [PrM = rEL] -10 to P20 [PRM = Abs] 0 to P20
P20	11.0	Pr2	Probe value at 20 mA or at 5V	BAR: [PrM = rEL] PA4 to 50.0 [PrM = AbS] PA4 to 50.0 PSI: [PrM = rEL] PA4 to 725 [PrM = AbS] PA4 to 725 dKP: [PrM = rEL] PA4 to 500 [PrM = AbS] PA4 to 500
LPL	-0.5	Pr1	Lower pressure limit for superheat regulation	PA4 to P20
MOP	11.0	Pr1	Maximum operating pressure threshold	LOP to P20
LOP	-0.5	Pr1	Lowest operating pressure threshold	PA4 to MOP
dML	30	Pr1	Delta MOP-LOP opening variation	0 to 100
MSH	80.0	Pr1	Maximum superheat alarm threshold	[LSH to 144°F] [LSH to 80.0°C]
LSH	1.0	Pr1	Minimum superheat alarm threshold	[0 to MSH °F] [0.0 to MSH °C]
SHy	0.5	Pr1	Superheat alarm hysteresis	[1°F to 45°F] [0.1°C to 25.5°C]

Table 23-1 - Default Setting Values (Continued)

SHd	3.0	Pr1	Superheat alarm activation delay	0 to 42.0(252) (min.10sec)
FrC	100	Pr1	Fast-recovery constant	0 to 100
DEFROST				
dPA	P2	Pr1	Defrost probe A	nP(0) - P1(1) - P2(2) - P3(3) - P4(4) - P5(5)
dPb	nP	Pr1	Defrost probe B	nP(0) - P1(1) - P2(2) - P3(3) - P4(4) - P5(5)
dPE	100	Pr1	Virtual probe percentage (defrost temperature)	0 to 100 (100=dPA, 0=dPb)
tdF	EL	Pr1	Defrost type	EL(0) - in(0)
EdF	in	Pr1	Defrost mode: Interval	in(1)
Srt	150	Pr1	Heater setpoint during defrost	[-67°F to 302°F] [-55.0°C to 150°C]
Hyr	2.0	Pr1	Differential for heater	[1°F to 45°F] [0.1°C to 25.5°C]
tod	255	Pr1	Time out for heater	0 to 255 (min.)
dtP	0.1	Pr1	Minimum temperature difference to start defrost	[1°F to 90°F] [0.1°C to 50.0°C]
ddP	60	Pr1	Delay before starting defrost	0 to 60 (min.)
d2P	n	Pr1	Defrost with two probes	n(0) - Y(1)
dtE	8.0	Pr1	Defrost termination temperature (Probe A)	[-67°F to 122°F] [-55.0°C to 50.0°C]
dtS	8.0	Pr1	Defrost termination temperature (Probe B)	[-67°F to 122°F] [-55.0°C to 50.0°C]
idF	6	Pr1	Interval between defrosts	0 to 120 (hours)
MdF	30	Pr1	Defrost Maximum duration	0 to 255 (min.)
dSd	0	Pr1	Start defrost delay	0 to 255 (min.)
dFd	it	Pr1	Display during defrost	rt(0) - it(1) - SEt(2) - dEF(3)
dAd	30	Pr1	Defrost display time out	0 to 255 (min.)
Fdt	0	Pr1	Drain down time	0 to 255 (min.)
dPo	n	Pr1	Defrost at start-up	n(0) - Y(1)
dAF	0.0	Pr1	Defrost delay after continuous cycle	0 to 24.0(144) (hours.10min)
FAN				
FPA	P2	Pr1	Fan probe A	nP(0) - P1(1) - P2(2) - P3(3) - P4(4) - P5(5)
FPb	nP	Pr1	Fan probe B	nP(0) - P1(1) - P2(2) - P3(3) - P4(4) - P5(5)
FPE	100	Pr1	Virtual probe percentage (fan management)	0 to 100 (100=FPA, 0=FPb)
FnC	O-n	Pr1	Fan operating mode	C-n(0) - O-n(1) - C-y(2) - O-y(3)
Fnd	10	Pr1	Fan delay after defrost	0 to 255 (min.)
FCt	10	Pr1	Temperature differential to avoid short cycles of fans	[0°F to 90°F] [0.0°C to 50.0°C]

Table 23-1 - Default Setting Values (Continued)

FSt	2.0	Pr1	Fan stop temperature	[-67°F to 122°F] [-55.0°C to 50.0°C]
FHy	1.0	Pr1	Fan stop differential	[1°F to 45°F] [0.1°C to 25.5°C]
Fod	0	Pr1	Fan activation time after defrost (without compressor)	0 to 255 (min.)
Fon	0	Pr1	Fan ON time	0to15 (min.)
FoF	0	Pr1	Fan OFF time	0to15 (min.)
trA	UAL	Pr2	Kind of regulation for modulating output	UAL(0) - rEG(1) - AC(2)
SOA	80	Pr2	Fixed speed for fan	AMi to AMA
SdP	30.0	Pr2	Default Dew Point value	[-67°F to 122°F] [-55.0°C to 50.0°C]
ASr	1.0	Pr2	Differential for fan / offset for anti sweat heater	[-45°F to 45°F] [-25.5°C to 25.5°C]
PbA	5.0	Pr2	Proportional band for modulating output	[1°F to 45°F] [0.1°C to 25.5°C]
AMi	0	Pr2	Minimum output for modulating output	0 to AMA
AMA	100	Pr2	Maximum output for modulating output	AMi to 100
AMt	200	Pr2	Time with fan at maximum speed	0 to 255 s
ALARM				
rAL	P1	Pr1	Probe for temperature alarm	nP(0) - P1(1) - P2(2) - P3(3) - P4(4) - P5(5) - tEr(6)
ALC	Ab	Pr1	Temperature alarm configuration	rE(0) - Ab(1)
ALU	10	Pr1	High temperature alarm setting	[0°F to 90°F or ALL to 302°F] [0.0°C to 50.0°C or ALL to 150.0°C]
ALL	-30	Pr1	Low temperature alarm setting	[0°F to 90°F or -67°F to ALU°F] [0.0°C to 50.0°C or -55.0°C to ALU]
AHy	1.0	Pr1	Differential for temperature alarm	[1°F to 45°F] [0.1°C to 25.5°C]
ALd	15	Pr1	Temperature alarm delay	0 to 255 (min.)
dLU	150	Pr2	High temperature alarm setting (defrost probe)	[0°F to 90°F or dLL to 302°F] [0.0°C to 50.0°C or dLL to 150.0°C]
dLL	-55	Pr2	Low temperature alarm setting (defrost probe)	[0°F to 90°F or -67°F to dLU°F] [0.0°C to 50.0°C or -55.0°C to dLU]
dAH	1.0	Pr2	Differential for temperature alarm (defrost probe)	[1°F to 45°F] [0.1°C to 25.5°C]
ddA	15	Pr2	Temperature alarm delay (defrost probe)	0 to 255 (min.)
FLU	150	Pr2	High temperature alarm setting (fan probe)	[0°F to 90°F or FLL to 302°F] [0.0°C to 50.0°C or FLL to 150.0°C]
FLL	-55	Pr2	Low temperature alarm setting (fan probe)	[0°F to 90°F or -67°F to FLU°F] [0.0°C to 50.0°C or -55.0°C to FLU]

Table 23-1 - Default Setting Values (Continued)

FAH	1.0	Pr2	Differential for temperature alarm (fan probe)	[1°F to 45°F] [0.1°C to 25.5°C]
FAd	15	Pr2	Temperature alarm delay (fan probe)	0 to 255 (min.)
dAo	1.3	Pr1	Delay of temperature alarm at start-up	0 to 24.0(144) (hours. 10min)
EdA	30	Pr1	Alarm delay at the end of defrost	0 to 255 min
dot	15	Pr1	Temperature alarm exclusion after door open	0 to 255 min
Sti	nu	Pr2	Stop regulation interval	"nu"(0) to 24.0(144) (hour. 10min)
Std	3	Pr2	Stop duration	1 to 255 min
oA6	AUS	Pr2	Sixth relay output configuration	CPr(0) - dEF(1) - FAn(2) - ALr(3) - LiG(4) - AUS(5) - db(6) - OnF(7)
oA7	ALr	Pr2	Modulating output configuration (if CoM=oA7)	CPr(0) - dEF(1) - FAn(2) - ALr(3) - LiG(4) - AUS(5) - db(6) - OnF(7)
CoM	Cur	Pr2	Modulating output configuration	CUr(0) - tEn(1) - PM5(2) - PM6(3) - oA7(4)
AOP	cL	Pr1	Alarm relay polarity	OP(0) - CL(1)
iAU	n	Pr1	Auxiliary output independent from ON/OFF state	n(0) - Y(1)
DIGITAL INPUTS				
i1P	cL	Pr1	Digital input 1 polarity	OP(0) - CL(1)
i1F	dor	Pr1	Digital input 1 configuration	EAL(0) - bAL(1) - PAL(2) - dor(3) - dEF(4) - AUS(5) - LiG(6) - OnF(7) - Htr(8) - FHU(9) - ES(10) - Hdy(11)
d1d	15	Pr1	Digital input 1 activation delay	0 to 255 (min.)
i2P	cL	Pr1	Digital input 2 polarity	OP(0) - CL(1)
i2F	LiG	Pr1	Digital input 2 configuration	EAL(0) - bAL(1) - PAL(2) - dor(3) - dEF(4) - AUS(5) - LiG(6) - OnF(7) - Htr(8) - FHU(9) - ES(10) - Hdy(11)
d2d	5	Pr1	Digital input 2 activation delay	0 to 255 (min.)
i3P	cL	Pr1	Digital input 3 polarity	OP(0) - CL(1)
i3F	ES	Pr1	Digital input 3 configuration	EAL(0) - bAL(1) - PAL(2) - dor(3) - dEF(4) - AUS(5) - LiG(6) - OnF(7) - Htr(8) - FHU(9) - ES(10) - Hdy(11)
d3d	0	Pr1	Digital input 3 activation delay	0 to 255 (min.)
nPS	15	Pr1	Number of pressure switch activation before lock	0 to 15
OdC	F-C	Pr1	Compressor and fan status when open door	no(0) - FAn(1) - CPr(2) - F-C(3)
rrd	30	Pr1	Outputs restart after door open alarm.	0 to 255 (min.)

Table 23-1 - Default Setting Values (Continued)

CLOCK				
CbP	Y	Pr1	Clock presence	n(0) - Y(1)
Hur	---	Pr1	Current hour	---
Min	---	Pr1	Current minutes	---
dAY	---	Pr1	Current day	Sun(0) - SAt(6)
Hd1	nu	Pr1	First weekly day	Sun(0) - SAt(6) - nu(7)
Hd2	nu	Pr1	Second weekly day	Sun(0) - SAt(6) - nu(7)
Hd3	nu	Pr1	Third weekly day	Sun(0) - SAt(6) - nu(7)
ILE	0.0	Pr1	Energy saving cycle start during workdays	0 - 23.5(143)(hours.10min)
dLE	0.0	Pr1	Energy saving cycle length during workdays	0 to 24.0(144)(hours.10min)
ISE	0.0	Pr1	Energy saving cycle start during holidays	0 - 23.5(143)(hours.10min)
dSE	0.0	Pr1	Energy saving cycle length during holidays	0 to 24.0(144)(hours.10min)
HES	0.0	Pr1	Temperature increasing during Energy Saving cycle	[-54°F to 54°F] [-30.0°C to 30.0°C]
Ld1	nu	Pr1	Workdays First defrost start	0.0 to 23.5(143) - nu(144) (hours.10min)
Ld2	nu	Pr1	Workdays Second defrost start	Ld1 to 23.5(143) - nu(144) (hours.10min)
Ld3	nu	Pr1	Workdays Third defrost start	Ld2 to 23.5(143) - nu(144) (hours.10min)
Ld4	nu	Pr1	Workdays Fourth defrost start	Ld3 to 23.5(143) - nu(144) (hours.10min)
Ld5	nu	Pr1	Workdays Fifth defrost start	Ld4 to 23.5(143) - nu(144) (hours.10min)
Ld6	nu	Pr1	Workdays Sixth defrost start	Ld5 to 23.5(143) - nu(144) (hours.10min)
Sd1	nu	Pr1	Holidays First defrost start	0.0 to 23.5(143) - nu(144) (hours.10min)
Sd2	nu	Pr1	Holidays Second defrost start	Sd1 to 23.5(143) - nu(144) (hours.10min)
Sd3	nu	Pr1	Holidays Third defrost start	Sd2 to 23.5(143) - nu(144) (hours.10min)
Sd4	nu	Pr1	Holidays Fourth defrost start	Sd3 to 23.5(143) - nu(144) (hours.10min)
Sd5	nu	Pr1	Holidays Fifth defrost start	Sd4 to 23.5(143) - nu(144) (hours.10min)
Sd6	nu	Pr1	Holidays Sixth defrost start	Sd5 to 23.5(143) - nu(144) (hours.10min)
ENERGY SAVING				
ESP	P1	Pr1	Energy saving probe selection	nP(0) - P1(1) - P2(2) - P3(3) - P4(4) - P5(5) - tEr(6)
HES	0.0	Pr1	Temperature increasing during Energy Saving	[-54°F to 54°F] [-30.0°C to 30.0°C]
PEL	n	Pr1	Energy saving activation when Light switched off	n(0) - Y(1)

Table 23-1 - Default Setting Values (Continued)

LAN MANAGEMENT				
LMd	y	Pr2	Defrost Synchronization	n(0) - Y(1)
dEM	y	Pr2	Defrost end Synchronization	n(0) - Y(1)
LSP	n	Pr2	SET-POINT Synchronization	n(0) - Y(1)
LdS	n	Pr2	Display Synchronization (temperature sent via LAN)	n(0) - Y(1)
LOF	n	Pr2	ON/OFF Synchronization	n(0) - Y(1)
LLi	y	Pr2	Light Synchronization	n(0) - Y(1)
LAU	n	Pr2	AUX Synchronization	n(0) - Y(1)
LES	n	Pr2	Energy Saving Synchronization	n(0) - Y(1)
LSd	n	Pr2	Remote probe displaying	n(0) - Y(1)
LPP	n	Pr2	Pressure value sent in LAN	n(0) - Y(1)
StM	n	Pr2	Cooling request from LAN enable compressor relay	n(0) - Y(1)
PROBE CONFIGURATIONS				
P1C	NtC	Pr2	P1 configuration	nP(0) - Ptc(1) - ntc(2) - PtM(3)
o1	0.0	Pr2	P1 calibration	[-21°F to 21°F] [-12.0°C to 12.0°C]
P2C	NtC	Pr2	P2 configuration	nP(0) - Ptc(1) - ntc(2) - PtM(3)
o2	0.0	Pr2	P2 calibration	[-21°F to 21°F] [-12.0°C to 12.0°C]
P3C	NtC	Pr2	P3 configuration	nP(0) - Ptc(1) - ntc(2) - PtM(3)
o3	0.0	Pr2	P3 calibration	[-21°F to 21°F] [-12.0°C to 12.0°C]
P4C	NtC	Pr2	P4 configuration	nP(0) - Ptc(1) - ntc(2) - PtM(3)
o4	0.0	Pr2	P4 calibration	[-21°F to 21°F] [-12.0°C to 12.0°C]
P5C	420	Pr2	P5 configuration	nP(0) - Ptc(1) - ntc(2) - PtM(3) - 420(4) - 5Vr(5)
o5	0.0	Pr2	P5 calibration	[-21°F to 21°F] [-12.0°C to 12.0°C]
P6C	PtM	Pr2	P6 configuration	nP(0) - Ptc(1) - ntc(2) - PtM(3)
o6	0.0	Pr2	P6 calibration	[-21°F to 21°F] [-12.0°C to 12.0°C]

Table 23-1 - Default Setting Values (Continued)

SERVICE				
CLt	---	Pr1	ON/OFF percentage (C.R.O.)	(read only)
tMd	---	Pr1	Time remaining before next defrost activation (only for interval defrost)	(read only)
LSn	---	Pr1	Number of devices in LAN	1 to 8 (read only)
LAn	---	Pr1	List of address of LAN devices	1 to 247 (read only)
OTHER				
Adr	1	Pr1	MODBUS address	1 to 247
rEL	---	Pr1	Firmware release	(read only)
Ptb	4	Pr1	Parameter table	(read only)
Pr2	---	Pr1	PR2 menu access	(read only)

Appendix A - Alternate MODBUS COM Wiring Method for E2, XR, XM, and XEV Devices

Overview

To simplify MODBUS communication wiring with E2, (both Standard and Enhanced versions) XR, XM, and XEV series devices, the alternate method outlined below may be used.

Wire Type

Use Belden 8761 or equivalent cable.

Shield

DO NOT connect the shield to the device. Keep the shield continuous throughout a network segment. The shield must be twisted together and insulated with electrical tape or heatshrink at each device within a network segment. Securely connect the shield to an earth grounded chassis at each end of a network segment.

Termination

Each network segment must be biased and terminated at the E2 controller's end (all three jumpers in the MOD position for E2 Enhanced, or all three jumpers in the UP position for E2 Standard) and terminated with a 150 ohm resistor at the other end of the network segment (150 ohms between the two communication wires).

Recommended

For reliable communication on some installations, it may be necessary to connect a 100 ohm resistor between the XR, XM, or XEV device's previously identified ground terminal and earth ground.

Some E2 MODBUS COM Ports Can Support Two Network Segments

For E2 Enhanced 4.x Controller Hardware

COM2 supports two network segments: one on connector RS485-COM2A, and the second on connector RS485-COM2B.

COM4 supports two network segments: one on connector RS485-COM4A, and the second on connector RS485-COM4B.

COM6 only supports one network segment on connector RS485-COM6.

For E2 Standard 3.x Controller Hardware

COM2 supports two network segments: one on connector RS485-1A, and the second on connector RS485-1B.

For information on the maximum recommended number of XR, XM, and XEV devices for each network segment (load and bandwidth calculations), contact Copeland Technical Support at 770-425-2724.

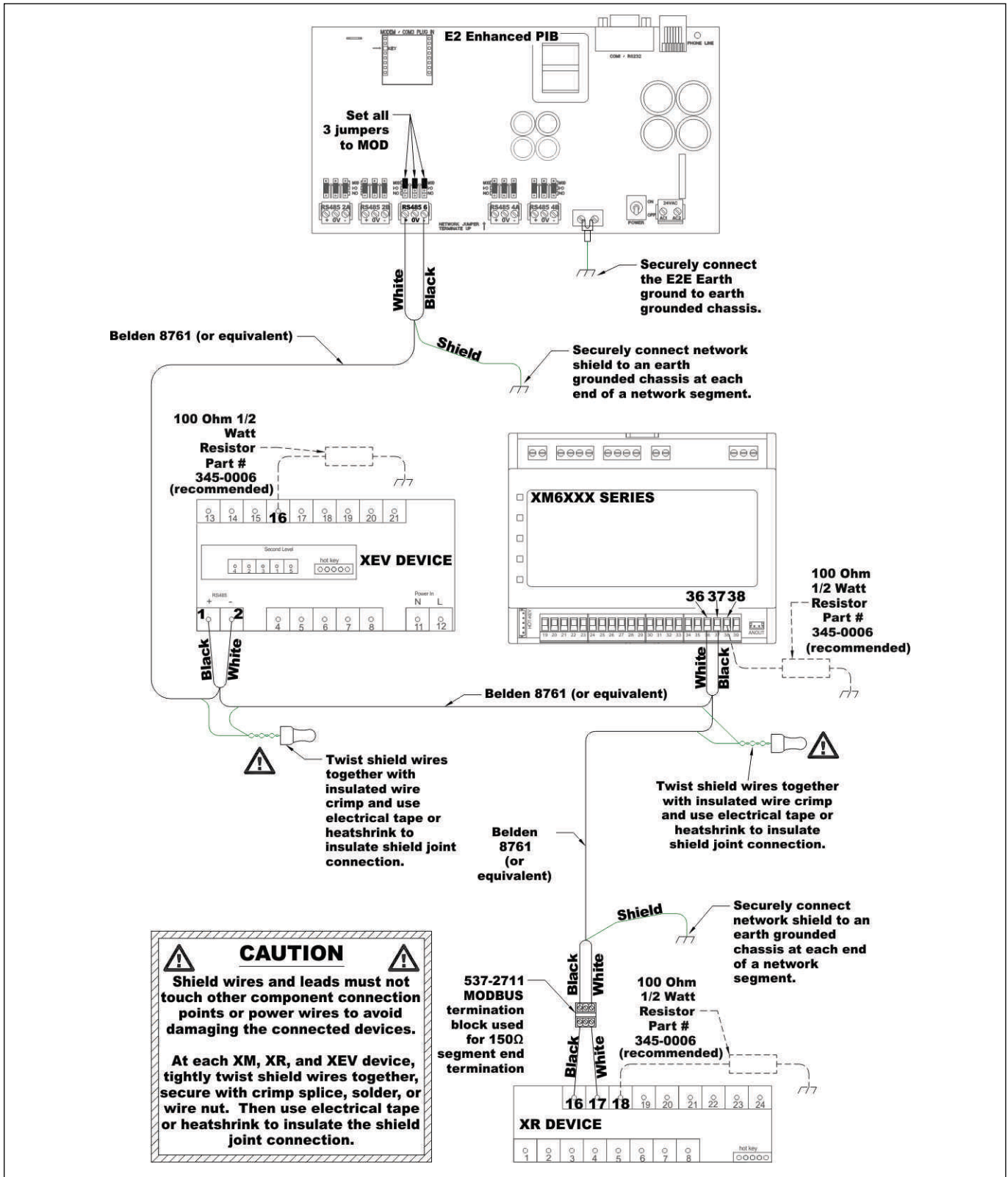

Figure 1 - MODBUS COM Wiring Diagram

Visit our website at copeland.com/en-us/products/controls-monitoring-systems for the latest technical documentation and updates.
For Technical Support call **833-409-7505** or email **ColdChain.TechnicalServices@Copeland.com**

The contents of this publication are presented for informational purposes only and they are not to be construed as warranties or guarantees, express or implied, regarding the products or services described herein or their use or applicability. Copeland reserves the right to modify the designs or specifications of such products at any time without notice. Responsibility for proper selection, use and maintenance of any product remains solely with the purchaser and end-user.
©2024 Copeland is a trademark of Copeland LP.